

Teaching
Guide 1

MATHS

Patterns, Sorting and Matching
Learning Numbers to 5
First Shapes and Measurement

SUE GILBERT

Real Learning

Real Maths

Really Fun!

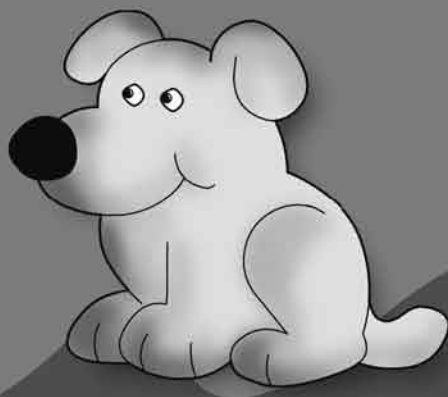

OXFORD
UNIVERSITY PRESS



Contents

Introduction	iv
Section 1: Patterns Sorting and Matching ... 1	
Drawing stripes.....	2
Drawing circles.....	3
Copying patterns (1).....	4
Colouring patterns (1).....	5
Finishing patterns (1).....	6
Copying patterns (2).....	7
Colouring patterns (2).....	8
Finishing patterns (2).....	9
Matching pictures (1), (2), and (3).....	10
Sorting into groups.....	11
Seeing the differences (1), (2), and (3).....	13
Matching one-for-one (1), and (2).....	16
Drawing the missing parts (1), (2), (3) and (4).....	18
Drawing the same number.....	19
Section 2: Learning Numbers to 5	21
Matching one-for-one.....	22
Making patterns of 1.....	22
Colouring groups of 1.....	23
Writing the number 1.....	24
Making patterns of 2.....	25
Drawing groups of 2.....	26
Writing the number 2.....	27
Making patterns of 3.....	27
Drawing groups of 3.....	28
Writing the number 3.....	28
Finding the matching number from 1–3.....	29
Writing the matching number from 1–3.....	30
Making patterns of 4.....	31
Drawing groups of 4.....	31
Writing the number 4.....	32
Making patterns of 5.....	32
Drawing groups of 5.....	33
Writing the number 5.....	33
Joining the matching sets of 3–5.....	34
Finding the matching number from 1–5.....	35
Drawing matching objects from 1–5.....	37
Writing the matching numbers from 1–5.....	40
Colouring by numbers.....	43
Section 3: First Shapes and Measurement	47
Finding one longer.....	48
Drawing one longer.....	49
Feeling surfaces.....	49
Comparing two areas.....	51
Finding one larger.....	52
Drawing one larger.....	52
Finding one heavier.....	54
Finding 'hot' things.....	55
Finding what comes first (1) and (2).....	56
Finding balls.....	57
Finding boxes.....	58
Sorting 3D shapes.....	60
Finding circles.....	60
Finding squares.....	62
Finding triangles.....	62
Finding rectangles.....	63
Making patterns.....	64
Making pictures.....	65
Drawing something 'on top of'.....	65
Drawing something 'between'.....	66
Finding your way (1), and (2).....	67

Introduction

Given that no two students are alike in the way they learn, and no two teachers are alike in the way they teach, it would be impossible to provide a set of definitive plans for any lesson. The lesson plans in this teaching guide are therefore exactly as the title states – guides.

The material and suggestions they contain will, I hope, help teachers to deliver their lessons effectively, but only if modified by the teacher's own knowledge and understanding of their students' interests, strengths, and weaknesses.

This crucial, early stage of a child's education forms the basis for their learning throughout life. If the time spent in the classroom is fun, and success is reinforced through praise, students will be eager and active learners. As well as verbal praise, make sure that the students' books are collected regularly and plenty of positive feedback is given through the use of stickers, stars, smiley faces, etc.

At the same time, any problems that are not addressed at this stage may affect future learning adversely, so make sure that potential problems are identified early and that remedial action is taken when and where necessary.

Although each of the lessons is intended to take one 35–40 minute period, please be flexible as far as timing is concerned and only move on from one topic to the next when you are certain that no misunderstandings remain. A little extra time spent on learning the basics at this stage will ensure steady progress through the later stages.

The book is full of illustrations of objects that should be familiar to the students. Encourage them to talk about these objects in either English or their first language and share their ideas. Similarly, explanations and instructions given in English can be repeated in the students' first language when necessary to reinforce understanding.

Practical work is of great importance in making classroom maths relevant to the world outside. To enable this, ask the students to help you collect simple, everyday items that can be used for practical classroom activities. Items such as plastic bottle tops, buttons, large beads, clean yoghurt pots, plastic bottles of different shapes and sizes, clean, empty packets from toothpaste, soap, tissues, cereal and other food items boxes, and cardboard tubes from kitchen and toilet rolls (these can be sterilized by placing them in a microwave oven for a minute or two) will all be useful for introductory and recapitulation activities. Begin the collection well in advance of when you will need to use the items.

A list of specific materials is given at the start of each lesson plan so that these can be prepared in advance.

Please ensure that all visual aids are large enough and clear enough to be seen by the students sitting furthest away from the teacher. When small items are used, make it clear to the students that they should not be placed in the mouth, nose, ears, etc. and always collect all the materials at the end of the lesson.

Students work at different rates and to accommodate this, those who finish the work ahead of the others can be asked to colour some of the pictures in the textbook. Colouring is an excellent way to develop fine, motor skills and hand-eye co-ordination, so encourage students who do not have time to colour in class to take their books home and do this for homework.

I hope that both teachers and students will enjoy using the **Excel Maths** series and that a lot of excellent learning will be the result.

Patterns Sorting and Matching

What's in this section?

Preparing for numbers is a vital step along the path to learning Maths. This section will prepare the child for the important, first skills of:

- seeing patterns
- sorting into groups
- matching up items.

These skills are very important for children to develop the ability to count and work with numbers later on.

The teacher will need to work actively with them for each activity so they understand what they are expected to do on each page. The children will listen as the teacher reads out the instruction for each activity, and then perform the tasks in the correct sequence.

Drawing stripes Pages 2-3

Teaching Objectives

- to teach the meaning of the terms *plain* and *striped*
- to help students recognize a pattern of horizontal or vertical stripes
- to help students begin to draw patterns of horizontal or vertical stripes

Learning Outcomes

Students should be able to

- use the terms *plain* and *striped* correctly to describe patterns found on common objects.
- recognize a pattern of horizontal or vertical stripes.
- begin to draw patterns of horizontal or vertical stripes.

Lesson 1 Pages 2-3 Drawing stripes

Materials required

- a plain item e.g. a T-shirt or towel; examples of clothing or other items with horizontal and vertical stripes e.g. socks, shirt, pinafore, bag, ribbons, T-shirt, tea-towel, towel;

Introduction

Show the students one of the plain items and ask them to name the colour. Elicit that it is of one colour and we therefore say that it is plain.

Next show them one of the vertically, striped items and ask them to talk about the colours.

Explain that it is not plain because it has more than one colour.

Establish that the pattern is made of lines of different colours and introduce the term striped.

Show them other items with vertical stripes and talk about the patterns. Do not use the term vertical, but say that the stripes go up and down, e.g. This bag has a pattern of red and green stripes. The stripes go up and down.

Next show them an item with horizontal stripes and ask them to decide whether it is plain or striped. Elicit that it is also striped, but that the stripes are in a different direction; use the terms across or from side to side to describe the horizontal stripes. Talk about the patterns.

Student Activity

Ask the students to open their books at pages 2-3.

Look at the pictures and talk about each of them. At this stage, discussion can be in English or the students' first language.

Picture 1- Lions are wild animals but sometimes you can see them in a zoo. Has any student seen a lion in a zoo? Lions are dangerous animals so they have to be kept in cages that are barred. The bars look like stripes. Do the stripes of the cage go up and down, or across?

Picture 2 - The T-shirt has a striped pattern. The stripes go across the T-shirt. Does any student have a striped T-shirt like the one shown? What colours are the stripes? If they bought a striped T-shirt, what colours would they choose?

Picture 3 - The gift is wrapped in striped paper. Which way do the stripes go? When do we give gifts? What could be inside the box?

Picture 4 – The pot has a pattern of stripes. Which way do the stripes go? What might be stored in the pot? Ask the students to draw three or four vertical stripes in the air with their forefinger; then ask them to draw some horizontal stripes in the same way. Ask them to look at the picture of the cage and trace the dotted lines with their forefinger. Ask them to do the same on the other pictures. After this, ask them to use their pencil or a coloured pencil and trace the stripes on all the pictures. Give them a set amount of time to complete the exercises on the two pages. Stress that it is better to take more time and work neatly than to rush and produce careless work. As the students work, walk around the room and make positive comments about their progress. Students who finish the exercises can begin to colour the pictures.

Recapitulation

Divide the class into two or more teams and divide the board into the same number of columns. Ask members of each team to come to the board in turn and draw one or two stripes (depending on ability) on the board in the direction you state. Give points for accuracy and neatness. Ask the students to bring something/a picture of something from home that is striped, for the next lesson.

Drawing circles Pages 4 and 5

Teaching Objectives

- to teach the meaning of the term *circle*
- to help students recognize a circle on its own or as part of a more complex object
- to help students to begin to draw circles

Learning Outcomes

Students should be able to

- use the term *circle* correctly to describe circular objects.
- recognize a circle on its own or as part of a more complex object.
- begin to draw circles.

Lesson 2 Pages 4-5 Drawing circles

Materials required

- a large sheet of card with a large drawing of a circle on it; card circles of different sizes; Blu-tack, masking tape, or similar adhesive material; objects that have parts that are circular, e.g. an orange, a clock face, the top of a jar or mug, a can of soft drink, items with patterns of spots or circles, etc; a piece of paper or card with a circle drawn on it for each student, (and a few spares) with the student's name written on it;

Introduction

Begin the lesson with a 'show and talk' activity using the striped objects that the students have brought from home. These items can be used to make a display in the classroom.

Next fix the large drawing of the circle on the board and teach the students the term circle. Talk about the shape, explaining that it is round and that, unlike stripes, it is not easy to see where the shape begins and ends.

Use your finger to trace around the circumference of the circle several times, starting at a different point each time.

Ask the students to draw a large circle in the air, and then smaller and smaller ones, starting at different points on the circumference each time.

Show the students the card circles of different sizes and explain that each of them is the same shape – a circle.

Student Activity

Ask the students to open their books at pages 4–5.

Look at the pictures and talk about them.

Picture 1 – a bicycle. How many wheels does a bicycle have? What shape is a wheel? How many circles can they see in the drawing? Are they all wheels? Do any of the students have tricycles or bicycles with extra stabilizing wheels?

Picture 2 – sunflowers. Do the students have flowers growing in their gardens? Are there any flowers in the school grounds? What colour are sunflowers? (If you have access to the internet you could show them a copy of van Gogh's famous painting of Sunflowers.)

Picture 3 – three oranges. Do the students like to eat oranges? Why is it good to eat oranges? How/where do oranges grow in Pakistan? What other fruits are round?

Picture 4 – four faces. Talk about the expressions on the faces. Are they happy/sad/rude? Are they men or women?

Ask the students to draw a circle in the air with their finger, and then another on their desk.

Ask them to look at the picture of the bicycle and trace the dotted circles with their forefinger.

Ask them to do the same on the other pictures.

After this, ask them to use their pencil to trace all the circles. Give them a set amount of time to complete the exercises on the two pages. Stress again that it is better to take more time and work neatly than to rush and produce careless work.

As the students work, walk around the room and make positive comments about their progress. Students who finish the exercises can begin to colour the pictures.

Recapitulation

Show the students some of the items you have brought into the classroom and help them to identify the circles. You could ask individual students to come to the front of the class and trace the circle with their finger.

Give each student a drawing of a circle and ask them to draw their own face on it. Use the faces to decorate the classroom.

Copying patterns (1) Pages 6–7

Teaching Objectives

- to help students copy a pattern of stripes, circles or half-circles by tracing

Learning Outcomes

Students should be able to

- copy a pattern of stripes, circles or half-circles by tracing.

Lesson 3 Pages 6-7 Copying patterns (1)

Materials required

- sets of coloured pencils or crayons; sheets of black paper and class sets of coloured chalks;

Introduction

Ask the students to recall the different patterns they have been learning about (vertical/horizontal stripes/circles).

Draw a circle on the board and rub out the top half of it. Explain that the shape that remains is half a circle, or a semi-circle. Trace the shape with your finger and ask the students to copy you to draw a semi-circle in the air and then on their desk.

Student Activity

Ask the students to open their books at pages 6–7.

Talk about each pattern and point out to the students that the pattern continues across both pages. Ask them to trace over each pattern with their finger, continuing across both pages.

Explain the task and talk about the different colours they might use for the different patterns.

Ask the students to complete the tasks and stress that it is more important to work neatly and accurately than to finish first.

Recapitulation

The students may need to work in pairs or small groups in order to have access to the coloured chalks.

Give each student a sheet of black paper and ask them to use the chalks to draw a pattern of stripes, circles or semi-circles.

Use the patterns to decorate the classroom.

Colouring patterns (1) Pages 8-9

Teaching Objectives

- to show that a pattern can be created by alternating the colours of identical shapes

Learning Outcomes

Students should be able to

- create a pattern by colouring identical shapes in alternating colours.

Lesson 4 Pages 8–9 Colouring patterns (1)

Materials required

- building blocks or similar items in several different colours; if these are unavailable, cut identical shapes out of different coloured sheets of card or paper; Blu-tack, masking tape, or similar adhesive material; coloured pencils or crayons;

Introduction

Ask the students to recall what they did in the previous lesson; they may need to look at pages 6–7 to recall that they made rows of identical shapes.

Now use six blocks of the same colour, or fix six identical card shapes on the board to make a similar row of identical shapes. Ask the students to name the colour of the blocks/shapes.

Now remove alternate blocks/shapes and replace them with blocks/shapes of a different colour. Ask the students say what has changed and explain that by using two colours you have created a pattern.

Point to each block/shape and say its colour e.g. red, yellow, red, yellow, red, yellow, and encourage the students to tell you which colour should come next.

Repeat this with other shapes/objects/colour combinations and ask individual students to add the next two or three elements to the pattern.

Student Activity

Ask the students to open their books at pages 8–9.

Look at the example and talk about the pattern. The students should be able to explain that the pattern is made up of alternating circles of dark green and light green. Ask them to imagine another circle at the end of the row and to predict what colour it would be.

Discuss the other rows of pictures on pages 8–9. Ask the students to suggest how they might colour them, using two colours for each row, to make a pattern.

Make sure that every student has access to coloured pencils or crayons and give them a set amount of time to complete the patterns on the two pages. Again stress that it is more important to work neatly and accurately than to finish first.

Recapitulation

When the students have completed the work, ask individual students to show their work to the class and talk about how they have used two different colours to create each pattern.

Finishing patterns (1) Pages 10–11

Teaching Objectives

- to help students identify the elements of a given pattern

Learning Outcomes

Students should be able to

- continue a given pattern.

Lesson 5 Pages 10-11 Finishing patterns (1)

Materials required

- sheets of gift-wrapping paper/samples of fabric/items of clothing with simple patterns e.g. stripes, spots or stars, or drawings of simple patterns on plain paper; a class set of large paper snakes cut out of A3 sheets of paper or thin card; coloured pencils or crayons;

Introduction

Show the students one of the pattern samples that you have prepared. Ask them to identify the main element of the pattern e.g. stripes, stars, etc., and any colour repeats. Ask them to predict how the pattern would continue. Do this for all of your samples.

Student Activity

Ask the students to open their books at pages 10–11. Look at the first snake and ascertain that the pattern on the snake is stripes. Point out that the first stripe is black and ask the students what colour the second stripe should be; it could be black, or they may decide to use alternating colours. Ask what colour the third stripe should be (black). Ask the students to trace over the dotted lines to complete the first stripes and then continue the pattern (using one or two colours) across both pages so that it extends over the whole of the snake. Help them to keep the distance between the stripes as equal as possible.

Look at the second and third snakes and discuss the elements of each pattern and how they should be continued. Give the students a set amount of time to complete the patterns on the two snakes. Students who finish ahead of the others could colour the spots on the snakes

Recapitulation

Give each student one of the large cut out snakes and ask them to draw and colour their own pattern on it.

Discuss their ideas for patterns before they begin and check each student's work before they begin to use colour. The snakes can be used to decorate the classroom.

Copying patterns (2) Pages 12-13

Teaching Objectives

- to help students copy a pattern of familiar shapes by tracing

Learning Outcomes

Students should be able to

- copy a pattern of familiar shapes by tracing.

Lesson 6 Pages 12 -13 Copying patterns (2)

Materials required

- coloured board markers or chalks; large sheets of plain paper or card divided by ruled lines into five or six rows; Blu-tack, masking tape or similar adhesive material;

Introduction

Use the coloured markers or chalks to draw a repeating pattern on the board similar to those shown on page 12 of the textbook, for example triangle, triangle, star, star, triangle, triangle, star, star. Ask the students to identify the elements of the pattern and the number of times each occurs, and ask them to predict what would come next. If you have used different colours, they should also predict the next colour.

Draw a second pattern on the board and after discussing it, ask individual students to draw the next elements.

Ask the students to suggest elements to make a third pattern on the board, and draw it.

Student Activity

Ask the students to open their books at pages 12–13. Look at the first pattern and ask the students to name the two shapes that make up the pattern. Then ask a student to describe the pattern on page 12 (two squares, then two circles). Look at the continuation of the pattern outlined on page 13 and check that it is the same. Ask the students to suggest how they might colour the shapes while retaining the pattern.

Look at the other patterns to identify the elements and how they have been used to create each pattern.

Give the students a set amount of time to complete the exercises on the two pages and when you have checked their work, ask them to add colour.

Recapitulation

Play a team game:

Divide the students into teams of four or six and fix a large sheet of paper on the board for each team, so that the students can reach them easily.

Ask each team to choose two elements to make a pattern. The first member of the team should come and draw the first element of the pattern on the first row of the team's sheet of paper.

When s/he has finished, the other members of the team should follow in turn, each adding an element to the pattern until the width of the paper is filled. Award team points for accuracy and neatness.

Repeat the activity with different patterns for the other rows on the sheets of paper until they are full.

Colouring patterns (2) Pages 14–15

Teaching Objectives

- to help students create patterns by alternating the colours of identical shapes

Learning Outcomes

Students should be able to

- create patterns by alternating the colours of identical shapes.

Lesson 7 Pages 14-15 Colouring patterns (2)

Materials required

- sheets of paper and gummed shapes if available, or an assortment of sets of coloured counters, buttons, Lego blocks, pencils, paper shapes, plastic bottle tops, or similar items that can be used to make patterns;

Introduction

Draw a pattern on the board made up of two alternating shapes in the same colour; draw a second pattern below it made of one shape in alternating colours.

Ask the students to discuss the differences in the patterns.

Ask them to look back at pages 8–9 in their textbooks and recall the patterns they made by using two different colours.

Student Activity

Ask the students to open their books at pages 14 -15 and explain that the task will be the same as the one they completed in the earlier lesson. Discuss the different objects used to make each pattern and ask the students to suggest possible colours they could use. Again stress the importance of careful, neat work before giving the students a set amount of time to complete the patterns on the two pages. Select some examples of good work to be shown to the class and discussed.

Recapitulation

Ask the students to work in pairs. Give each pair some materials from which they can make a pattern of identical objects using two different colours; it could be as simple as two red crayons/ bottle tops and two blue crayons/bottle tops.

Ask each pair to show their pattern to the class and talk about it.

Finishing patterns (2) Pages 16-17

Teaching Objectives

- to help students identify the elements of a given pattern

Learning Outcomes

Students should be able to

- continue a given pattern.

Lesson 8 Pages 16-17 Finishing patterns (2)

Materials required

- large, coloured, wooden beads and laces if available; if unavailable, draw on a sheet of A4 paper two or three 'necklaces' like those shown on p 17. Photocopy a class set of the sheets; coloured pencils or crayons;

This lesson can follow the structure of lesson 5. Students can look back at pages 10–11 to recall the task.

Recapitulation

If beads and laces are available, ask the students to make their own necklaces and talk about the pattern they have made. If they are unavailable, give each student a photocopied sheet and ask them to colour the 'necklaces' to make a repeating pattern.

Matching pictures (1), (2), and (3) Pages 18–23

Teaching Objectives

- to teach the meaning of the term *matching*
- to help students match pictures of identical, familiar objects
- to help students shade pictures of identical objects in the same colour

Learning Outcomes

Students should be able to

- identify matching objects.
- match pictures of identical, familiar objects.
- shade pictures of identical objects in the same colour.

Lesson 9 Pages 18–19 Matching pictures (1)

Materials required

- coloured pencils or crayons; sets of three items, two of which are exactly the same, the third being different in colour or shape, e.g. paper cups, textbooks, packets of juice, toys, pencils, etc.; a cd/dvd/youtube clip of Old Macdonald's Farm;

Introduction

Show the students two different textbooks and ask them to explain the difference. Now add a third book that is the same as one of the original two and ask the students to identify the two books that are the same. Ask questions to elicit from the students that they are the same because they are the same shape, size and colour. Explain that we use the term matching to mean that two or more items are exactly the same.

Show them a set of three more objects and ask them to identify the matching pair. Repeat this for the other sets you have prepared, stressing each time that the objects that are said to be matching are identical in every way.

Student Activity

Ask the students to open their books at pages 18–19. Look at all the items on the two pages, name them and talk about where they can be seen. Ask the students to look at the two green horses and discuss whether or not they are matching. Then ask them to draw a line with a pencil between the two pictures. Ask them to identify the other matching pairs of animal pictures on page 18 and to draw lines connecting the pairs. Then ask the students to colour the pairs of animal pictures so that they match; they should choose a different colour for each pair. Repeat this for the pictures on page 19.

Give the students a set amount of time to complete the exercises on the two pages and then correct their work as a class.

Recapitulation

Sing the song Old Macdonald's Farm, making sure to include a cow (moo-moo), horse (neigh-neigh), sheep (baa-baa), and duck (quack-quack), among the animals. If you have access to a computer in the classroom there are excellent versions of the songs available on youtube; these can be saved on a memory stick and used on a laptop in the classroom.

Lesson 10 Pages 20-23 Matching pictures (2) and (3)

Materials required

- six sets of three matching shapes cut from coloured card, e.g. red triangles, blue squares, yellow circles, orange stars, pink rectangles, green semi-circles; Blu-tack, masking tape or similar adhesive material; coloured pencils or crayons; a tape/cd/dvd/youtube clip of the different versions of the songs mentioned in the recapitulation section;

Introduction

Fix three of the sets of matching shapes on the board in a random order (e.g. as on page 21 of the book).

Revise the names of the shapes and the colours as you do so. When they are all in position, ask the students to look carefully at the shapes and say whether any of them are matching. Ask a student to come to the board and draw a line between two matching shapes, then ask a second student to draw a line to the third matching shape. Repeat this for the other two sets of shapes. Remove these shapes and repeat the activity using the other three sets of shapes that you have prepared, with different students.

Student Activity

Ask the students to open their books at page 20 and look at the pictures.

Talk about the different types of boats (rowing boat, sailing boat, and motorboat). Ask them if they can draw lines between the matching sets of boats. Do the same for the vegetables on page 21.

Give the students a set amount of time to colour the sets of items shown on the two pages so that they are matching, using a different colour for each set.

Depending on time, continue with the work on pages 22-23, or complete this in the next lesson.

Recapitulation

Use a tape/cd/dvd/youtube clip to teach the students the song Row, Row, Row Your Boat and/or The Wheels on the Bus Go Round and Round.

Sorting into groups Pages 24-25

Teaching Objectives

- to teach students to count groups of 2, 3, and 4 items
- to help students sort matching objects into groups according to their physical characteristics

Learning Outcomes

Students should be able to

- count groups of 2, 3, and 4 items.
- sort matching objects into groups according to their physical characteristics.

Lesson 11 Pages 24–25 Sorting into groups

Materials required

- sets of four objects e.g. books, pencils, toy cars, balls; if possible, a set of ten inflated balloons on strings, in a mixture of three different colours, / a set of ten other objects e.g. plastic balls in three colours / a set of ten cut-out shapes in three different colours; red, yellow and green coloured pencils or crayons; coloured board markers or chalks;

Introduction

If necessary, begin by teaching/revising counting to four. Use the sets of objects: place them one by one on your desk or a table where they are visible to all the students, as you place each one, count and encourage the students to count with you. Reinforce the activity by asking the students to count round the class from 1 to 4.

Draw some sets of shapes on the board e.g. two triangles, four circles, three stars, and ask the students to count them with you.

Next show the students the inflated balloons or the set of ten objects that you have prepared. Ask three students to come to the front of the class and each should take a balloon / ball of a different colour.

Ask another student to come, take a balloon, and stand with the student who has the same colour balloon / ball. Repeat this until all the balloons have been taken and there are three groups of students. Count how many balloons/balls there are in each group.

Student Activity

Ask the students to open their books at page 24 and make sure that every student has access to red, yellow and green coloured pencils or crayons.

Ask them to count how many green fish they can see in the bowl. Explain that there are also three red fish in the bowl and ask them to use their red coloured pencils to make a small mark on three of the fish; ask them to mark the remaining four fish with yellow. Ask the students to colour the fish carefully in the correct colours. When they have finished, count how many fish there are in each colour group.

Ask the students to look at page 25 and ask them to mark the correct number of balloons with the correct colour as you read the instructions to them. Complete the colouring and count how many balloons there are in each colour group.

Recapitulation

Divide the students into three or four teams and divide the board into the same number of columns.

Ask the first student from each team to come to the board and draw a given group of shapes, e.g. two red circles; three green stripes; four blue, smiley faces, etc. Award points for accuracy and neatness.

Seeing the differences (1), (2), and (3)

Pages 26–31

Teaching Objectives

- to teach the meaning of the terms *different* and *difference*
- to help students identify an object that is different from others in the same set

Learning Outcomes

Students should be able to

- use the terms *different* and *difference* correctly.
- identify an object that is different from others in the same set.

Lesson 12 Pages 26–29 Seeing the differences (1) and (2)

Materials required

- a set of three objects that are the same and one that is different, e.g. three maths textbooks and one English textbook; coloured pencils or crayons;

Introduction

Show the students the set of four textbooks and ask if they are all the same. They should identify the one that is different. Introduce the term *different* and explain that it is used to describe something that is not the same as another thing. Ask the students if they can explain why the object is different and then sum up their responses using the phrase, 'The difference is!' On the board draw a row of four shapes, three of which are the same and one that is different, e.g. three circles and a triangle. Ask the students to identify the shape that is different and to explain the difference. Draw a circle round the object that is different. Repeat this several times, with different combinations of shapes, or shapes that differ in colour.

Student Activity

Ask the students to open their books at page 26. Look at the example and ask them to explain why one item has been circled. Draw their attention to the fact that the other pictures have all been coloured in the same colour.

Look at the next row of objects and ask the students to identify the one that is different from the others.

Ask them to draw a circle round it and discuss the difference.

Do this for all the exercises on pages 26–29, then ask the students to colour all the objects in each exercise that are the same. This may take more than one lesson.

Recapitulation

Go over all the exercises on pages 26–29 and discuss the differences again.

Draw a set of three matching shapes or objects on the board and ask a student to draw a fourth shape or object that is different from the others.

Lesson 13 Pages 30- 31 Seeing the differences (3)

Materials required

- class set of worksheet 1;

Introduction

Note—this activity needs to be handled sensitively to avoid upsetting the feelings of the students involved; choose the students carefully to avoid this.

Ask two students to stand in front of the class. Ask the rest of the class to identify similarities between the two students, e.g. both have short hair, both are wearing the same uniform, both are wearing the same shoes, etc. Then ask them to identify one or two differences between the two students, e.g. they are wearing different shoes/socks.

Student Activity

Ask the students to open their books at page 30. Explain the task and give them a set amount of time to complete the exercise. Discuss their answers, then ask them to complete the task on page 31.

Recapitulation

Ask students to complete worksheet 1.

Worksheet 1

Look carefully at the first picture. Look at the second picture and draw circles round the things that are different.

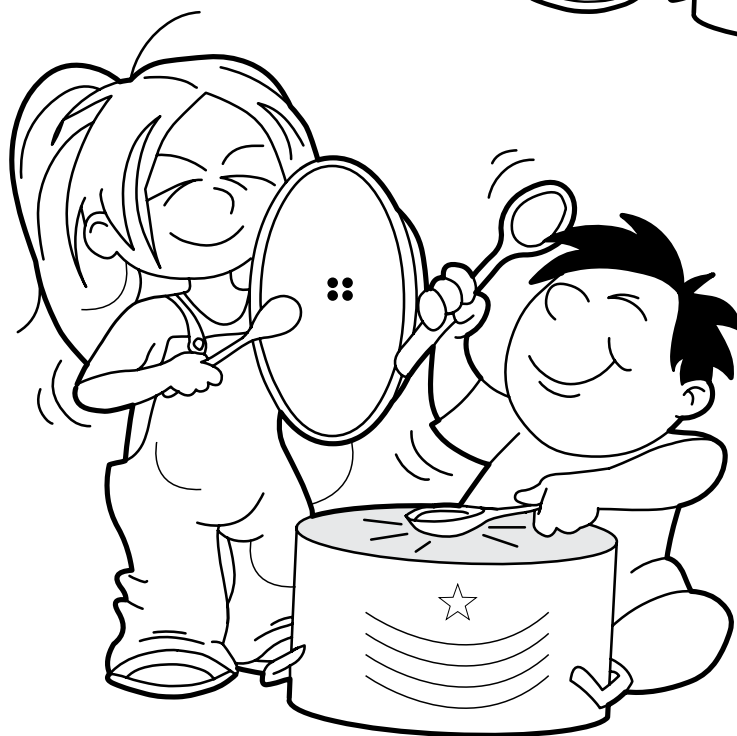

Matching one-for-one (1) and (2) Pages 32–35

Teaching Objectives

- to help students match pairs of related items

Learning Outcomes

Students should be able to

- match pairs of related items.

Lesson 14 Pages 32–35 Matching one-for-one (1) and (2)

Materials required

- a light ball; four caps or paper hats; tape/cd/dvd/youtube clip of Baa Baa Black Sheep; class set of worksheet 2;

Introduction

Revise counting from 1 to 4: ask the students to stand in a large circle with you. Throw the ball to a student and as you do so, say 1. The student who catches the ball should say 2 as s/he throws it to another student. Continue the throwing and counting to 4 and then start again from 1. If students can already count higher, continue to 10 before beginning again from 1. If this activity is not possible, count round the class.

Ask the students to return to their seats and show them the four caps or hats. Count how many hats there are. Call a student to the front of the class and place a cap on his/her head. As you do so, count 1. Repeat this for the other three caps, counting 2, 3, and 4. Ask the students to decide if you should call another student; they should say no to because there are no more hats. Count again—one student, one hat; two students, two hats; three students, three hats; four students, four hats to indicate that the number of students matches the number of hats.

Student Activity

Ask the students to open their books at page 32. Look at the example and explain that calf is the word for a baby cow. Ask them to count the number of cows and the number of calves and establish that there are three of each. Point out the line that links the first cow to the first calf and then ask the students to join the other cows to their calves in the same way.

Look at the monkeys and bananas and discuss the fact that monkeys like to eat bananas. Count the number of monkeys and of bananas and establish that they match before drawing lines between them.

Ask the students to look at page 33 and discuss the pairs of items before asking them to match the pairs by drawing lines.

Continue with the objects on pages 34–35 in the same way. Give the students a set amount of time to complete the exercises on the two pages and then correct their work as a class.

Recapitulation

Give each student a copy of worksheet 2. Use the tape/cd/dvd/youtube clip to teach the rhyme and explain the text if necessary. Sing the rhyme two or three times and then ask the students to look at the work sheet and count the bags of wool and the people. Ask them to draw lines to match the bags of wool to the people.

Worksheet 2 Baa, Baa Black Sheep.

Sing the song and then match the bags of wool to the correct people.



Baa, baa black sheep,

Have you any wool?

Yes sir, yes sir,

Three bags full

One for the master,

One for the dame,

And one for the little boy

Who lives down the lane.

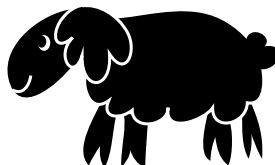
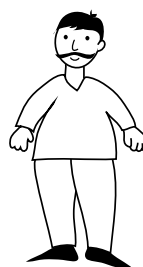
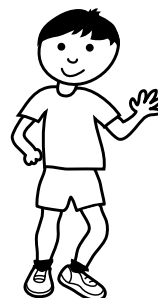

Drawing the missing parts (1), (2), (3), and (4) pages 36–43

Teaching Objectives

- to teach the meaning of the term *missing*
- to teach counting from 1–5
- to help students complete drawings by adding missing parts

Learning Outcomes

Students should be able to

- use the term *missing* correctly.
- to count a number of objects from 1–5 accurately.
- complete drawings by adding missing parts.

Lesson 15 Pages 36–39 Drawing the missing parts (1) and (2)

Materials required

- common objects from which something is missing, e.g. a shoe without a shoe lace, a teapot without a lid, a pencil case without any pencils, a vase of flowers without any water, an empty packet of sweets, a packet of juice without a straw, etc.; ten or twelve simple drawings or pictures from magazines, of common items, each on a piece of A4 paper; Blu-tack, masking tape or similar adhesive material;

Introduction

Teach/revise counting from 1–5 by counting round the class or using the ball and circle method (see Lesson 14).

Show the students one of the objects you have prepared. Ask them to look at it carefully and tell you what is wrong with it. When they respond, introduce the term *missing*; e.g. Yes, there is no shoe lace; the lace is missing.

Repeat this activity with the other objects you have prepared.

Student Activity

Ask the students to open their books at page 36 and look at the first example. Ask the students to count the number of babies, then the number of rattles. Establish that there are not enough rattles for all of the babies and that two more rattles are needed. Ask the students to draw the two rattles. You could also ask them to draw lines to join each baby with a rattle.

Repeat this activity with the other exercises on pages 36–37.

Recapitulation

Play a game: fix the drawings that you have prepared on the board and ask the students to look at them and name each item. Explain that they will have 2 minutes to look at the pictures and try to remember them. After the given time, take the pictures from the board, remove one of them and then replace the other pictures. The students should be able to tell you which picture is missing. Repeat this, taking away a different picture each time.

Lesson 16 Pages 40-43 Drawing the missing parts (3), and (4)

Materials required

- a tray containing ten to twelve small familiar items.

This lesson can be taught following the same structure as the previous lesson.

Recapitulation

Play a game: place the tray of familiar items in a place where all the students can see them clearly; pick up each item in turn, show it to the students and say what it is. After each item has been named, let the students look at the items for one to two minutes. Cover the tray and, without the students being able to see, remove one of the objects. Show the tray to the students again and ask them to tell you which item is missing.

Repeat the activity, removing a different item each time.

Drawing the same number pages 44-47

Teaching Objectives

- to help students draw, by copying, a given number of objects

Learning Outcomes

Students should be able to

- draw, by copying, a given number of objects.

Lesson 17 Pages 44-47 Drawing the same number

Materials required

- sheets of plain A4 paper, folded in half to make two A5-sized sections; pencils or crayons;

Introduction

Divide the board into two columns and draw a circle in the first column. Ask the students to tell you what they can see. Ask a student to come to the board and copy what you have drawn on the other side of the board. Add some detail to the circle to begin to make a face, e.g. a small circle in the centre for a nose; ask another student to copy it on the other circle. Continue adding to your 'face'; e.g. two eyes, two eyebrows, a mouth, four or five spikes of hair, two ears, etc. Each time, ask the students to count the parts you have added before one of them copies your work on the second 'face'.

Student Activity

Ask the students to open their books at page 44. Look at the first picture, ascertain that it shows one butterfly and talk about the different parts that make up the drawing—the two antennae, the two wings, one head, two body parts. Ask the students to trace over the lines to draw a copy of the butterfly.

Look at the other items on pages 44–45, count them and talk about any detail shown on them. Give the students a set amount of time to complete the exercises on the two pages and walk round and check their progress as they do so.

Continue with the work on pages 46–47 in the same way, taking another lesson if necessary.

Recapitulation

Give each student a piece of folded paper and ask them to work in pairs to copy each other's drawings.

They should decide which student should begin to draw first and use the left-hand side of the paper for that; the right-hand side of the paper will be used for the drawing started by the second student. This activity can be done over two lessons. Advise them to work slowly and carefully, building up the drawing in stages as you did on the board.

Learning Numbers to 5

What's in this section?

In this section, the child will explore the numbers 1 to 5 in a range of activities. The pupil will learn to:

- count from 1 to 5
- sort things into groups
- draw the numbers 1 to 5
- match up numbers
- write down numbers 1 to 5.

Laying this foundation early will help the child become a more enthusiastic and competent young mathematician.

The teacher will need to work actively with the children for each activity so they understand what they are expected to do on each page. The children will listen as the teacher reads out the instructions for each activity, and then perform the tasks in the correct sequence.

Matching one-for-one Pages 50-51

Teaching Objectives

- to revise counting from 1-5
- to help students match paired items

Learning Outcomes

Students should be able to

- count fluently from 1-5.
- accurately count up to five objects.
- match paired items.

Lesson 18 Pages 50-51 Matching one-for-one

Materials required

- an assortment of items that can be paired, e.g. a cup and saucer, a knife and fork, a bucket and spade, paints and a paint brush, a sock and shoe, a bat and ball, etc.; tape/cd/dvd/youtube clip of Baa Baa Black Sheep;

Introduction

Revise counting from 1-5 by counting round the class.

Place the selection of items you have prepared on a table so that paired items are not next to each other. Arrange the students to stand so that they can all see the items. Ask them to look carefully and see if they can decide which items go together. Ask individual students to make the pairs.

Student Activity

Ask the students to open their books at page 50. Count the number of faces with the students and then count the number of hats. Ask them to draw lines matching a hat to each face. Repeat the activity for the mice and the cheese.

Recapitulation

Sing Baa Baa Black Sheep with the students.

Making patterns of one Pages 52-53

Teaching Objectives

- to help students use two colours to make a repeating pattern of single elements

Learning Outcomes

Students should be able to

- use two colours to make a repeating pattern of single elements.

Lesson 19 Pages 52-53 Making patterns of one

Materials required

- coloured board markers or chalks; plain paper and coloured pencils or crayons or black/coloured, sugar paper and chalks;

Introduction

Draw a row of six to eight circles on the board; ask the students to describe what they can see. Explain that you want to make a pattern from your circles and ask them to suggest how you can do it. If necessary, ask them to look back at pages 8–9 of the textbook. Select two colours and colour the first two circles; ask the students to come to the board and continue the pattern.

Student Activity

Ask the students to open their books at pages 52–53. Look at the items in each row and count how many there are of each. Ask the students to suggest how they could be coloured to make patterns. Give the students a set amount of time to complete the exercises on the two pages. Stress the importance of working neatly and accurately and check their work as they complete the tasks.

Recapitulation

Give the students paper and crayons or chalks and ask them to design their own pattern of one; display the patterns in the classroom.

Colouring groups of one Pages 54-55

Teaching Objectives

- to help students make groups of three different single elements
- to help students use colours to identify different groups

Learning Outcomes

Students should be able to

- make groups of three different single elements.
- use colours to identify different groups.

Lesson 20 Pages 54-55 Colouring groups of one

Materials required

- 3 x 3 large shapes cut from white card or paper, e.g. three triangles, three circles and three squares; coloured markers; Blu-tack, masking tape or similar adhesive material; red, blue and green coloured pencils or crayons; from five or six (depending on number of students in the class) different coloured sheets of card, cut equal numbers of small squares so that the total number of squares is the same as the number of students and cut one larger square of each colour (see Recapitulation activity);

Introduction

Fix the large shapes on the board in a random display. Ask the students to name each of the shapes as you point to it. Establish that there are three different shapes.

Ask nine students to come to the board and each should take one of the shapes.

Ask how you could group the students with the shapes. The most probable response would be to group students with the same shapes together. Ask the nine students to form these three groups.

Now ask if there is another way to form matching groups and encourage the students to suggest three groups, each containing one of each shape. Ask the nine students to form these groups and then fix their set of three shapes back on the board, in a row.

Use the coloured markers to quickly draw e.g. green stripes on one set of shapes, red stripes on the second, and blue stripes on the third and talk about the fact that each set contains the same three, different shapes.

Student Activity

Make sure all students have access to red, green, and blue coloured pencils or crayons. Ask them to open their books at page 54 and tell you how many different kinds of animals they can see.

Then ask them to count how many of each animal. Begin with the cats and ask the students to place a red dot on the first cat, a blue dot on the second cat and a green dot on the third cat.

Repeat this for the other animals and then ask the students to colour all the animals in the colours they have marked on them.

Give the students a set amount of time to do this and then ask them if they can point to the e.g. group of red animals. Establish that each colour group contains one of each animal.

Repeat the activity for the animals on page 55.

Recapitulation

On the board fix the large squares of coloured cards and ask the students to name the colours.

Explain that one square of each colour will be needed to make a set. Give each student one small square of coloured card. First ask them to form groups of students who have cards of the same colour. When they have done this, ask them to move again and form groups so that each group contains one square of each colour, to make a set.

You can redistribute the cards so that students have different colours, and repeat the activity.

Writing the number 1 Pages 56–57

Teaching Objectives

- to help students to write the numeral 1

Learning Outcomes

Students should be able to

- write the numeral 1.

Lesson 21 Pages 56–57 Writing the number 1

Materials required

- tape/cd/dvd/youtubeclip of One Finger, One Thumb, Keep Moving

Introduction

Write a large number 1 on the board. Explain that it is the symbol used to represent one.

Trace over the figure with your finger and explain how it is written, beginning at the top and taking the pencil straight down to the line. Ask the students to draw the numeral in the air, repeating the verbal instructions as they do.

Ask them to look around the classroom to see if they can find anything that has the same shape as the number 1, e.g. a ruler, pencil, etc.

Student Activity

Ask the students to open their books at page 56. Explain that they need to make the number 1 several times to complete each of the pictures on the page. Before they begin to write, ask them to trace over each line with their forefinger. Stress the need to work slowly and carefully. Give the students a set amount of time to complete the exercises and then explain the tasks on page 57 and ask them to complete them.

Recapitulation

Use the tape/cd/dvd/youtube clip to teach the song One Finger, One Thumb, Keep Moving

Making patterns of two Pages 58–59

Teaching Objectives

- to help students use two colours to make a repeating pattern of two elements

Learning Outcomes

Students should be able to

- use two colours to make a repeating pattern of two elements.

Lesson 22 Pages 58–59 Making patterns of two

Materials required

- coloured board markers or chalks; plain paper and coloured pencils or crayons, or black/coloured sugar paper and chalks;

Introduction

Draw two rows of eight triangles on the board; ask the students to describe what they can see in the first row. Ask them how you can make a pattern from your triangles using two colours. They will probably suggest that you colour alternate triangles in different colours; do this with the first row of triangles. Then ask for a different idea for the second row of triangles and encourage them to suggest colouring two triangles in each colour. Ask students to come and do this and then to predict the colour of the next triangle.

Student Activity

Ask the students to open their books at pages 58–59. Look at the cats and establish that the pattern is made by two colours and that two cats are coloured in each colour. Ask the students to predict the colour of the next cat.

Look at the other items and ask the students to suggest how they can be coloured to make patterns of two elements, using two different colours. Give the students a set amount of time to complete the exercises on the two pages. Stress the importance of working neatly and accurately and check their work as they complete the tasks.

Recapitulation

Give the students paper and crayons or chalks and ask them to design their own patterns of two; display the patterns in the classroom.

Drawing groups of two Pages 60–61

Teaching Objectives

- to help students draw groups of two items by copying

Learning Outcomes

Students should be able to

- draw groups of two items by copying.

Lesson 23 Pages 60–61 Drawing groups of two

Materials required

- tape/cd/dvd/youtube clip of the song Head, Shoulders, Knees and Toes.

Introduction

Ask the students to think about their surroundings and name items that usually come in groups of two.

Begin by thinking about the human body—two legs, arms, hands, eyes, lips, ears, feet, thumbs, shoulders, knees, elbows, etc. Draw a basic body and head on the board and add to it the parts that the students name.

Move on to think about clothes e.g. socks, shoes, sleeves, trouser legs, gloves, two lenses in spectacles and a pair of earrings. If possible add these to the drawing or sketch them separately. Students may also suggest wheels on bicycles and motorcycles, two taps for a handbasin, twins, etc.

Student Activity

Ask the students to open their books at pages 60–61. Look at each exercise and discuss what must be added to complete each picture. Give the students a set amount of time to complete the pictures, stressing the need to work neatly rather than quickly.

Recapitulation

Use the tape/cd/dvd/youtube clip to teach the students the song Head, Shoulders, Knees and Toes.

Writing the number 2 Pages 62–63

Teaching Objectives

- to help students to write the numeral 2

Learning Outcomes

Students should be able to

- write the numeral 2.

Lesson 24 Pages 62–63 Writing the number 2

Materials required

- a mini-whiteboard for each student made by placing a sheet of plain white paper inside a plastic folder; a marker-pen for each student; an eraser made from tissues or kitchen roll;

This lesson can be taught following the same structure as lesson 21

Recapitulation

Give each student a mini-whiteboard, marker-pen and eraser and ask them to practise writing the numerals 1 and 2. Hold up one or two items and ask the students to write the correct number, then they should hold up their boards so that you can see their answers.

Making patterns of 3 Pages 64–65

Teaching Objectives

- to help students use two colours to make a repeating pattern of three elements

Learning Outcomes

Students should be able to

- use two colours to make a repeating pattern of three elements.

Lesson 25 Pages 64–65 Making patterns of 3

Materials required

- an assortment of sets of coloured counters, buttons, Lego blocks, pencils, paper shapes, plastic bottle tops, or similar items that can be used to make patterns of 3;

This lesson can be taught following the structure for lesson 22. Begin with rows of nine or twelve shapes on the board.

Recapitulation

Ask the students to work in pairs; give out the materials you have prepared and ask the students to use them to make their own patterns of 3. Encourage them to share their ideas with the class.

Drawing groups of 3 Pages 66–67

Teaching Objectives

- to help students draw groups of three items by copying

Learning Outcomes

Students should be able to

- draw groups of three items by copying.

Lesson 26 Pages 66–67 Drawing groups of 3

Materials required

- copy of the story of Goldilocks and the Three Bears;

Introduction

Hold up three identical objects, e.g. pencils or board markers and ask the students to count how many objects in the group. Ask them to hold up their own groups of three pencils.

Ask a student to make a group of three matching textbooks, school bags, or any other available classroom items. Count the elements of each group.

Student Activity

Ask the students to open their books at pages 66–67.

This lesson can be taught following the structure of lesson 23.

Recapitulation

Tell them the story of Goldilocks and the Three Bears.

Writing the number 3 Pages 68–69

Teaching Objectives

- to help students to write the numeral 3

Learning Outcomes

Students should be able to

- write the numeral 3.

Lesson 27 Pages 68-69 Writing the number 3

Materials required:

- mini-whiteboards, markers and erasers;

This lesson can be taught following the structure of lesson 21.

Recapitulation

Use the mini-whiteboards as for lesson 24, showing the students 1–3 items.

Finding the matching number from 1-3 Pages 70-71

Teaching Objectives

- to help students match a given number of articles to the numeral representing that number

Learning Outcomes

Students should be able to

- match a given number of articles to the numeral representing that number.

Lesson 28 Pages 70-71 Finding the matching number from 1-3

Materials required

- several flashcards of the numbers 1,2, 3; simple, picture flashcards of one, two, or three items or geometric shapes; Blu-tack, masking tape, or similar adhesive material; mini-whiteboards, markers and erasers, or sheets of plain paper and markers;

Introduction

Fix the numeral flashcards on the board out of sequence and read the numbers with the students.

Ask a student to put the cards in the correct order.

Fix one of the pictures on the board and ask the students to count the number of items shown.

Ask a student to come and choose the correct numeral flashcard to place below the picture.

Replace the numeral that has been used and repeat the activity with the other pictures you have prepared

Student Activity

Ask the students to open their books at pages 70–71.

Look at the example and ask them to explain why the numeral 1 has been circled.

Look at the second picture and count the snails. Ask the students to point to the number that should be circled, and then ask them to circle that number. Repeat this for the other pictures on the page if necessary and then give the students a set amount of time to complete the work on both pages before checking their work as a class.

Recapitulation

Give each student a mini-whiteboard or sheets of paper and a marker. Ask them to write the number (1–3) that you call out and ask them to hold up their work so that you can check it.

Writing the matching number from 1–3

Pages 72–73

Teaching Objectives

- to help students count accurately groups of one, two, and three items
- to help students record a number (1–3) by writing the correct numeral

Learning Outcomes

Students should be able to

- count accurately groups of one, two, and three items.
- record a number (1–3) by writing the correct numeral.

Lesson 29 Pages 72–73 Writing the matching number from 1–3

Materials required

- groups of one, two, or three items, e.g. pencils, rulers, mugs, books, toys, building blocks;

Introduction

Write the numerals 1, 2, and 3 on the board. Trace over them with your finger and ask the students to write the numbers in the air as you do so.

Show the students one of the groups of objects you have prepared and ask them to count them and then write the number in the air. Ask one student to come to the board and write the number. Repeat the activity for the other groups of objects.

Student Activity

Ask the students to open their books at pages 72–73. Look at the example, count the apples and check that the correct number has been written next to it. Look at the other pictures and ask the students to tell you which number should be written next to each of them. Give the students a set amount of time to complete the work on both pages before checking the work as a class.

Recapitulation

Play a game: ask the students to stand, then explain that you are going to ask them to do three different things. However, you will give the instructions using the numbers 1, 2, and 3. For example, when you say 1, they should bend down, when you say 2 they should stand with their arms above their heads, and when you say 3 they should stand with their arms and feet spread out. Anybody who performs the wrong action will be 'out' and have to sit down. Practise giving the number commands slowly. Once the game starts, speed up the instructions.

Making patterns of 4 Pages 74–75

Teaching Objectives

- to help students use two colours to make a repeating pattern of four elements

Learning Outcomes

Students should be able to

- use two colours to make a repeating pattern of four elements.

Lesson 30 Pages 74–75 Making patterns of 4

Materials required

- tape/cd/dvd/youtube clip of the song The Animals Went In Two By Two;

This lesson can be taught following the structure for lesson 22. Begin with rows of 8 or 12 shapes on the board.

Recapitulation

Use the tape/cd/dvd/youtube clip to teach the students the song The Animals Went In Two By Two.

Drawing groups of 4 Pages 76–77

Teaching Objectives

- to help students draw groups of four items by copying

Learning Outcomes

Students should be able to

- draw groups of four items by copying.

Lesson 31 Pages 76–77 Drawing groups of 4

Materials required

- plain paper; coloured pencils or crayons;

This lesson can be taught following the structure of lesson 23.

Recapitulation

Give the students plain paper and coloured pencils and crayons and then ask them to draw something with four legs. Discuss ideas first; it could be any four-legged animal, or a piece of furniture.

Writing the number 4 Pages 78-79

Teaching Objectives

- to help students to write the numeral 4

Learning Outcomes

Students should be able to

- write the numeral 4.

Lesson 32 Pages 78-79 Writing the number 4

Materials required

- flashcards of the numerals 1, 2, 3, and 4;

This lesson can be taught following the structure of lesson 21

Recapitulation

Play the game from lesson 29, adding a fourth instruction for number 4 and using the flashcards instead of calling out the numbers.

Making patterns of 5 Pages 80-81

Teaching Objectives

- to help students use two colours to make a repeating pattern of five elements

Learning Outcomes

Students should be able to

- use two colours to make a repeating pattern of five elements.

Lesson 33 Pages 80-81 Making patterns of 5

Materials required

- tape/cd/dvd/youtube clip to teach the students the song Five Little Speckled Frogs;

This lesson can be taught following the structure for lesson 22. Begin with rows of ten shapes on the board.

Recapitulation

Use the tape/cd/dvd/youtube clip to teach the students the song Five Little Speckled Frogs.

Drawing groups of 5 Pages 82–83

Teaching Objectives

- to help students draw groups of five items by copying

Learning Outcomes

Students should be able to

- draw groups of five items by copying.

Lesson 34 Pages 82–83 Drawing groups of 5

Materials required

- plain paper; coloured pencils or crayons or black/coloured sugar paper and coloured chalks;

This lesson can be taught following the structure of lesson 23.

Recapitulation

Give the students the drawing materials and ask them to draw their own patterns of 5.

Writing the number 5 Pages 84–85

Teaching Objectives

- to help students to write the numeral 5

Learning Outcomes

Students should be able to

- write the numeral 5

Lesson 35 Pages 84–85 Writing the number 5

Materials required

- tape/cd/dvd/youtube clip of Five Little Speckled Frogs.

This lesson can be taught following the structure of lesson 21

Recapitulation

Sing the song Five Little Speckled Frogs again. Ask students to hold up the fingers of one hand to represent the frogs, and bend one finger down each time a frog jumps into the pool.

Joining the matching sets of 3–5 Pages 86–87

Teaching Objectives

- to help students count groups of three, four, and five elements
- to help students match groups of the same size

Learning Outcomes

Students should be able to

- count accurately groups of three, four, and five elements.
- match groups of the same size.

Lesson 36 Pages 86–87 Joining the matching sets of 3–5

Materials required

- picture flashcards of three, four, and five familiar shapes or objects, e.g. three mugs, three balls, four socks, four circles, five triangles, five lollipops, etc.; Blu-tack, masking tape or similar adhesive material;

Introduction

Fix the flashcards on the board and ask the students to identify the items in each group and count them. As they count each set, write, (or ask a student to write) the number below the flashcard.

When all the sets have been counted, ask a student to find two sets that contain the same number of items and draw a line between them. Repeat this until all the sets have been matched.

Student Activity

Ask the students to open their books at pages 86–87. Look at each set of animals on page 86 and ask the students to count the number of animals in each set and write the number below/at the side of the box. Check that they have all counted correctly.

Look at the example and ask the students to explain why the line links the two boxes; ask the students to link the other matching sets in the same way. Give the students a set amount of time to complete the work on page 87 in the same way. Check their answers as a class.

Recapitulation

Ask the students to stand in a large circle, holding hands. Explain that they are going to make small circles of the number you say. The first circle will start with the students standing next to you and then the other students, in turn, should make their circles. Explain that there may be some students left over, but this is not a problem. Ask them to make circles of 2, 3, 4, and 5, and change your position in the circle so that different students begin the activity each time and it is not always the same students who are left out at the end.

Finding the matching number from 1-5

Pages 88-89

Teaching Objectives

- to help students match a given number of articles (1-5) to the numeral representing that number

Learning Outcomes

Students should be able to

- match a given number of articles (1-5) to the numeral representing that number.

Lesson 37 Pages 88-89 Finding the matching number from 1-5

Materials required

- class sets of numerals 1-5 made using resource sheet 1; picture flashcards of sets containing one-five items; tape/cd/dvd/youtube clip of the song Five Little Ducks Went Swimming One Day;

Resource sheet 1 Sets of numerals 1-5

Photocopy this sheet on to good quality paper or thin card and cut it up to make a set of numerals 1-5 for each student in the class.

1	2	3	4	5
1	2	3	4	5
1	2	3	4	5
1	2	3	4	5
1	2	3	4	5

Introduction

Give each student a set of numeral cards and ask them to place them on their desk face up in the correct order. This will enable you to check that each student has a full set of cards. Show the students one of the picture flashcards; ask them to count how many items there are in the set, and to hold up the correct numeral card so that you can see it clearly. Repeat this for all the flashcards.

Student Activity

Ask the students to open their books at pages 88–89. Look at the example and ask the students to explain why the number 2 has been circled. Look at the second picture and ask the students to decide which number should be circled. If necessary, count the items first. Depending on how much help the students require, either work through page 88 with them before asking them to continue with the work on page 89, or give them a set amount of time to complete the work on both pages before checking their work as a class.

Recapitulation

Teach them the song Five Little Ducks Went Swimming One Day.

Drawing matching objects from 1–5 Pages 90–91

Teaching Objectives

- to help students match a given number of articles (1–5) to the numeral representing that number

Learning Outcomes

Students should be able to

- match a given number of articles (1–5) to the numeral representing that number



Lesson 38 Pages 90–91 Drawing matching objects from 1–5

Materials required

- plastic/paper cups; small items such as Lego blocks, plastic bottle tops, wooden blocks, pencils, crayons etc.; sets of cards made using Resource sheet 2;

Resource sheet 2 Sets (1-5) cards

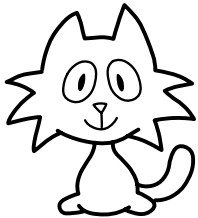
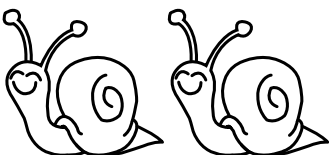
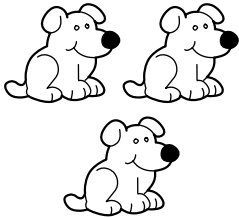
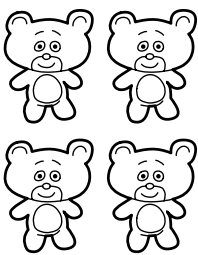
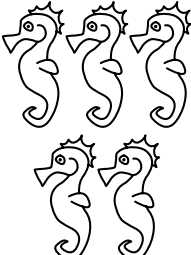
Photocopy these sheets on to good quality paper or thin card and cut them up to make enough sets of cards for students to work in pairs or groups of four. To keep sets separate, either use different coloured card/paper, or draw different symbols on the backs of each set.

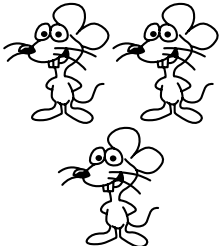
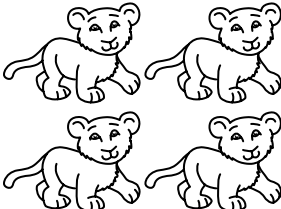
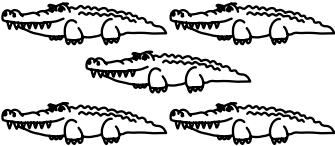
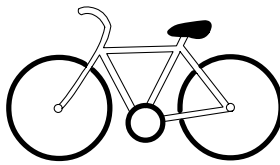
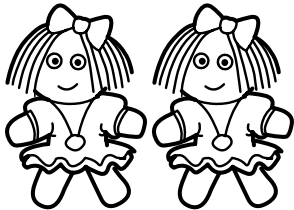
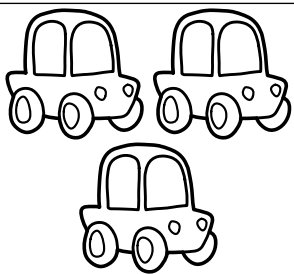
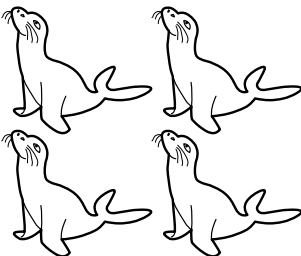
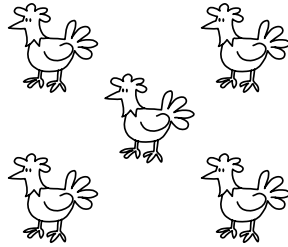

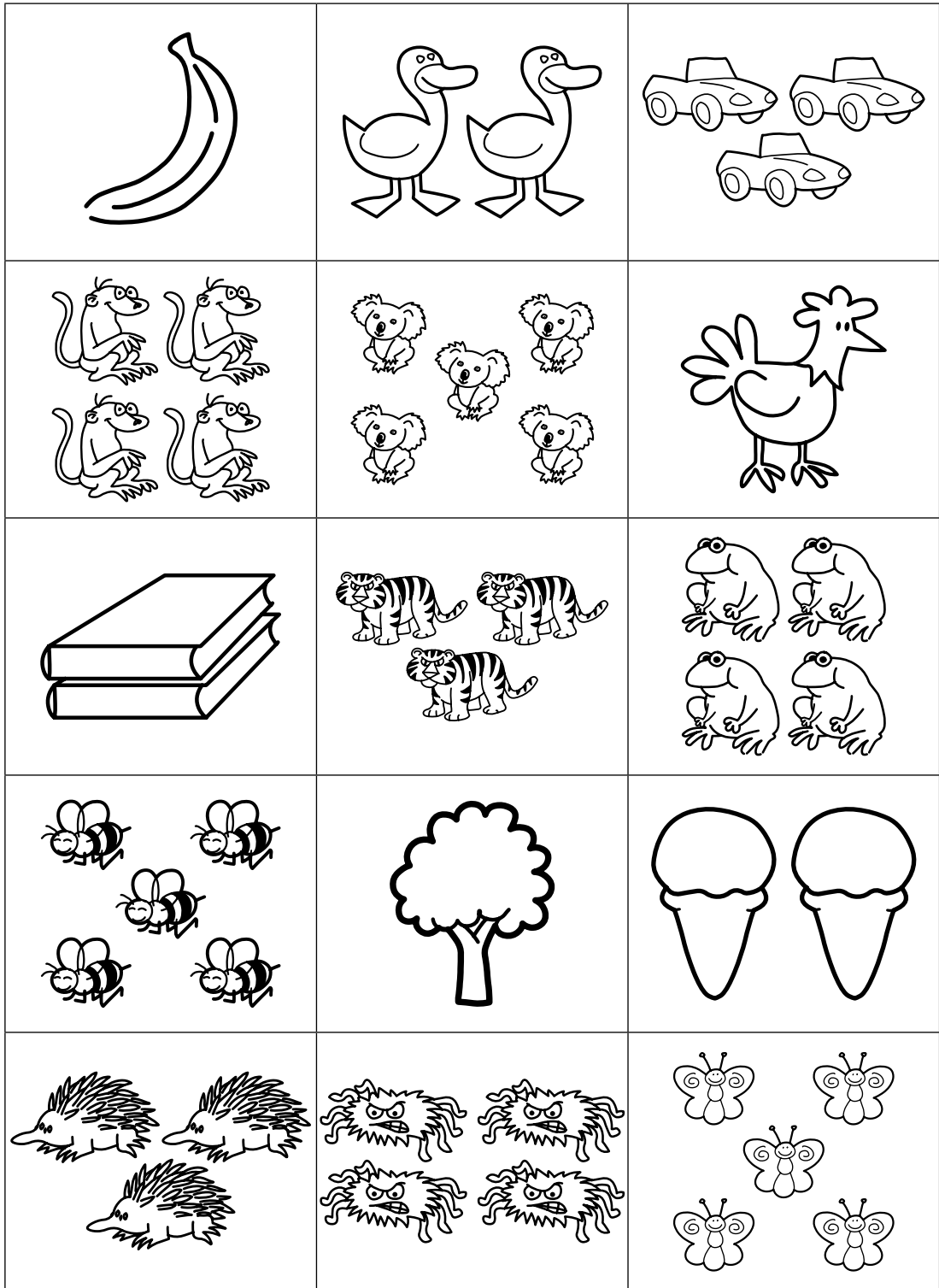
Introduction

Give each student a paper cup and about five or six of the small items.

Explain that you are going to write a number on the board and they will put that many items into their cup; partners will check each other's work.

When you have spent some time on this activity, collect the items and cups and draw one or two large cups on the board. Ask students to come to the board one at a time and draw in the cup, the number of objects that you say, e.g. four triangles, three Smarties, etc.

Student Activity

Ask the students to open their books at pages 90–91. Look at the example, count the biscuits, and establish that there are four biscuits in the jar because the number four is written at the top of the jar. Explain the rest of the tasks to the students and give them a set amount of time to complete the work. Stress that both accuracy and neatness are important.

Recapitulation

Use the Sets 1–5 cards to play Snap; students should play in groups of 3 or 4. The cards should be divided equally among the members of the group and placed face down. Remind the students not to look at their cards until they turn them over to add them to the pile. The student who says 'Snap' and puts a hand on the pile of cards when two cards showing the same size sets are played one after the other, wins all the cards on the pile and adds them to their own pile. You may wish to demonstrate the game before the students begin to play.

Writing the matching number from 1–5 Pages 92–93

Teaching Objectives

- to help students count accurately groups of 1–5 items
- to help students record a number (1–5) by writing the correct numeral

Learning Outcomes

Students should be able to

- count accurately, groups of 1–5 items.
- record a number (1–5) by writing the correct numeral.

Lesson 39 Pages 92–93 Writing the matching number from 1–5

Materials required

- sets of cards made from resource sheet 3; mini-whiteboards, markers, and erasers; picture flashcards of sets of 1–5 geometric shapes;

Resource Sheet 3 Memory cards 1-5

Photocopy these sheets on to good quality paper or thin card and cut them up to make enough sets of cards for students to work in pairs or groups of four. To keep sets separate, either use different coloured card/paper, or draw different symbols on the backs of each set.

1	2	3	4	5
1	2	3	4	5
1	2	3	4	5

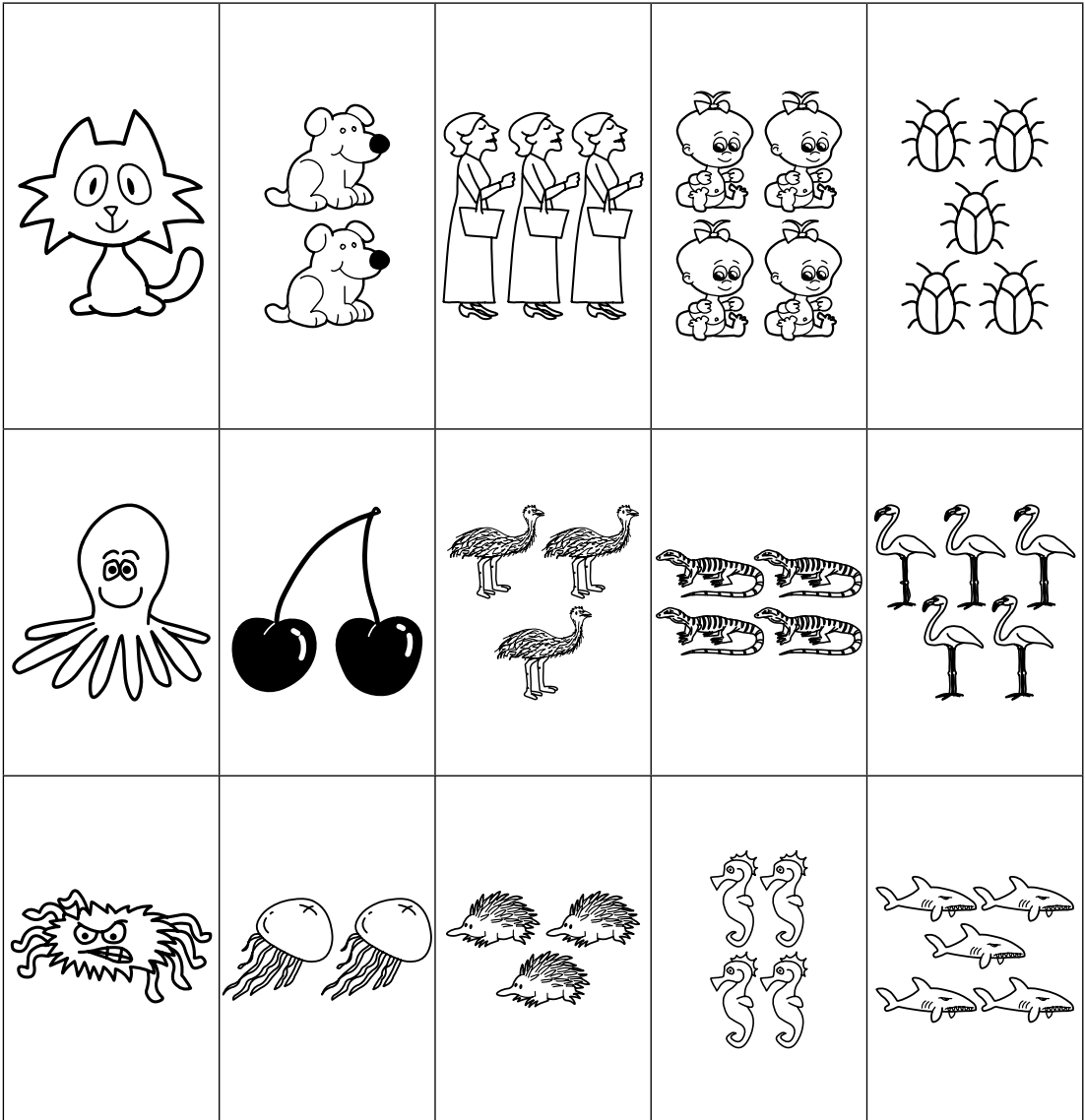

Introduction

Give each student a mini-whiteboard, marker, and eraser. Hold up one of the picture flashcards and ask the students to count the items, write the correct number on the mini-whiteboard and hold it up so that you can see the number. Repeat this for all the flashcards.

Student Activity

Ask the students to open their books at pages 92–93. Look at the example, count the dots and check that the correct number has been written next to the first dice. Look at the first beetle on page 93; ask the students to count the dots and write the number 1 in the space provided. Give the students a set amount of time to complete the work on both pages and then check their work as a class.

Recapitulation

Use the memory cards to play a game. The cards should be laid out carefully in 5 x 6 rows, face down. The first student should turn over one card and say what it shows. S/he should then turn over a second card in the same way. In order to win, s/he must turn over a number card and a picture card showing the same number of items. If they do not match, the cards should be turned back so that they are face down, and the second student takes a turn. If they match, the student keeps the cards. The student with most pairs of cards at the end of the game is the winner. [To make it easier, you might allow two matching numbers or two equal groups (rather than one of each) to win.]

Before the students play the game, demonstrate a few turns with a small group of students. Stress the importance of placing the cards back in the same position even when there are gaps so that they can remember the positions of the cards.

Colouring by numbers Pages 94–95

Teaching Objectives

- to help students to follow a colour key to colour a picture

Learning Outcomes

Students should be able to

- follow a colour key accurately to colour a picture

Lesson 40 Pages 94–95 Colouring by numbers

Materials required

- sets of coloured pencils or crayons; coloured chalks or board markers; tape/cd/dvd/ youtube clips of number songs.

Introduction

Draw a simple picture on the board, e.g. a large flower, a simple person. Write key numbers on different parts of it and draw a set of key triangles above the picture (as on page 94). Ask the students to suggest colours for each of the triangles and colour the triangles accordingly. Ask them to colour different parts of your drawing according to the key.

Student Activity

Ask the students to open their books at pages 94–95. Decide as a class which colour will be used for each triangle and colour the triangles accordingly. The students look at the picture and refer to the key to tell you which colour will be used for each part of the clown drawing. Ask them to complete the colouring as neatly and carefully as possible. When they have finished, ask them to choose their own colours and complete the picture on page 95.

Recapitulation



Sing some of the number songs that the students have learned.

At this point you may want to ask the students to complete assessment sheets 1a and 1b to assess learning.

Reassure them that the purpose of the assessment is to help you discover any topics that might need further teaching.

Assessment Sheet 1a Numbers 1-5

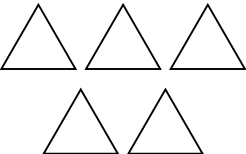
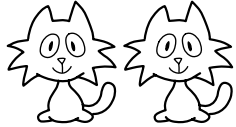
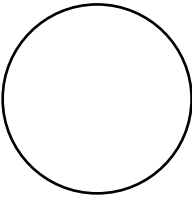
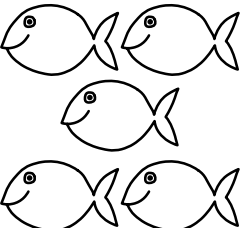
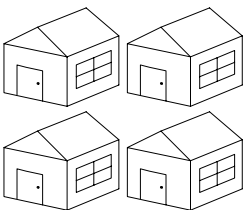
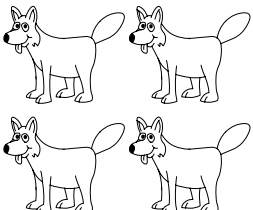
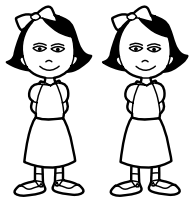
Count the items and write the correct number next to each set

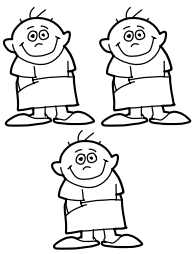
	3		
			
			
			
			

Assessment Sheet 1b Numbers 1-5

Draw the correct number of things in the box next to the number. You can draw any shape or object that you choose.

4	* * * *	5	
1		2	
3		4	
5		3	
2		1	

First Shapes and Measurement

What's in this section?

This section introduces the child to a range of different shapes and ways to measure them. The child will learn to:

- compare two or more objects by size, shape or position
- recognize two-dimensional and three-dimensional objects.

By looking at these shapes, the children will start to see that maths is all around them. The teacher can also help by encouraging the child to look for things to compare or measure around the school.

The teacher will need to work actively with the children for each activity so they understand what they are expected to do on each page. The children will listen as the teacher reads out the instruction for each activity, and then perform the tasks in the correct sequence.

Finding one longer Pages 98–99

Teaching Objectives

- to help students understand the meaning of the terms *long*, *longer*, *short*, and *shorter*
- to help students compare objects by length

Learning Outcomes

Students should be able to

- use the terms *long*, *longer*, *short*, and *shorter* correctly.
- compare objects by length.

Lesson 41 Pages 98–99 Finding one longer.

Materials required

- items to compare by length e.g. a long scarf or dupatta and a short scarf or dupatta, a long sock and a short sock, 2 lengths of rope, ribbon, or string, etc.; a large ball of string; scissors;

Introduction

Being aware of the students' sensitivities, introduce the terms long and short by referring to boy students who have short hair, and girl students who have long hair, e.g. Ali has short hair, and Faisal has short hair; Sadia has long hair and Alya has long hair.

Point to different students and ask them to say long or short to describe their hair.

Introduce the terms longer and shorter by comparing e.g. the hair of two boys: Ibrahim's hair is short, but Hamed's hair is shorter; Mariam's hair is long, but Nadia's hair is longer.

Ask the students to compare the hair lengths of pairs of students, e.g. X's hair is shorter than Y's.

Show the students the two scarves or dupattas and ask them to say which is long and which is short, e.g. the red scarf is long and the blue scarf is short. Do the same with the socks, rope or string, and other items.

Student Activity

Ask the students to open their books at pages 98–99. Explain that you are going to be looking for the items that are longer. Look at the example and ask why the balloon on the right has been circled, encouraging the students to use the term longer, when they answer. The students should explain that it has a long string/ the string of that balloon is longer than the other. Look at the other pairs of items on the page and discuss which should be circled.

Give them a set amount of time to complete the work on page 99 and check their work as a class.

Ask them to make sentences about the pairs of items using the target vocabulary.

Recapitulation

Ask students to do the task suggested at the bottom of page 99. They should work in pairs with a length of string which is as long as the taller of the pair. At the end of the activity ask the students to report back to the class about objects that are longer than their length of string.

Drawing one longer Pages 100–101

Teaching Objectives

- to help students draw by tracing

Learning Outcomes

Students should be able to

- draw by tracing.

Lesson 42 Pages 100–101 Drawing one longer

Materials required

- coloured markers or chalks; a wall chart, metre rule or other height-measuring equipment;

Introduction

Draw a horizontal line on the board. Ask a student to come to the board and, using a different colour, draw a longer line underneath it. Ask another student to draw a line that is longer than the second line.

Repeat the activity for a vertical line, wavy line, dotted line, etc.

Student Activity

Ask the students to open their books at pages 100–101. Look at the example and ask them to point to the picture of the girl with longer hair. Explain that they are going to trace shapes to draw things that are longer. Look at the worm and ask them to draw the longer worm by tracing over the dotted line. Look at the picture of the boy. (You might want to explain that the term tall/taller is used for people when they are standing. We can use long/longer to refer to the person's legs.) Continue with the work on page 101.

Recapitulation

Ask the students to line up in order of height. Use the chart/height-measuring equipment to measure the height of each student. Record the heights and make a bar chart to display in the classroom.

Feeling surfaces Pages 102–103

Teaching Objectives

- to help students understand the terms *rough* and *smooth*
- to encourage the students to explore different textures
- to help students describe the surfaces of common objects as rough or smooth

Learning Outcomes

Students should be able to

- use the terms *rough* and *smooth* correctly.
- describe correctly the surfaces of common objects as rough or smooth.

Lesson 43 Pages 102–103 Feeling surfaces

Materials required

- sets of samples of materials with different textures, e.g. pieces of sandpaper, aluminium foil, velvet, towelling, steel wool, satin, plastic, cotton wool, tile, carpet, grass matting, wire mesh, astroturf, etc; crayons; small (A5) sheets of plain paper; collection of small denomination coins;

Introduction

Divide the class into small groups and give each group a set of the materials you have prepared. Encourage the students to feel the different surfaces and talk about them with the other members of their group. After a few minutes draw their attention to the sandpaper and ask them to describe how it feels; introduce the term *rough*. Then ask them to feel the satin or velvet and describe how it feels; introduce the term *smooth*. Ask the groups to divide the samples into two groups according to texture (*rough/smooth*); compare their results and talk about the textures they prefer and those they dislike. Can they suggest other materials with rough or smooth textures?

Student Activity

Ask the students to open their books at pages 102–103 and make sure they all have access to crayons. Explain the task to them and before they begin the practical work, ask them to predict whether the different surfaces will be rough or smooth. Demonstrate how to carry out the work before asking them to do it. If they remain in their groups, each starting with a different surface, and move from one surface to the next together, it will prevent any area becoming overcrowded.

Recapitulation

Talk about the surfaces and the shading in their books; What are the patterns from the rough surfaces like?

What are those from the smooth surfaces like?

Give each student a sheet of plain paper; if there are trees in the school grounds, take them outside and show them how to make bark rubbings; these can be used to make a classroom display. Try to find out the names of the trees and compare the patterns from different trees. If there are no trees, remain indoors and give each student a coin. Show them how to make a rubbing of each face of the coin.

Comparing two areas Pages 104–105

Teaching Objectives

- to teach the meaning of the terms *large*, *larger*, and *area*
- to help students compare the areas of two similar objects

Learning Outcomes

Students should be able to

- use the term *area* correctly to indicate the amount of space covered by an object.
- use the terms *large* and *larger* correctly.
- compare the areas of two similar objects and decide which of them is *larger*.

Lesson 44 Pages 104–105 Comparing two areas

Materials required

- sets of three objects, one small, one large, and one larger than the second, to compare by size, e.g. books/ sheets of card/ plants/ plastic bags, mugs, plastic bottles, etc.; pieces of chalk;

Introduction

First teach the meaning of *large* and *larger* by showing the students the first set of items you have prepared. Show them a small object and establish that it is a small e.g. plastic bottle. Show them the large bottle and establish that it is a large plastic bottle;(you can explain that *large* means the same as *big*); finally show them the third bottle and establish that it is also large, and it is larger than the other bottles.

Repeat this activity with the other sets of objects you have prepared; ask questions e.g. Which book is larger? to encourage the students to use the terms *large* and *larger*.

To teach the meaning of the term *area*, draw round a small book that you have placed on a sheet of paper on a desk where all the students can see it. Remove the book and quickly shade the space inside the lines. Explain that this is the space that was covered by the book, and it is called the *area* of the book. Repeat the activity with a larger book and then compare the areas and decide which is larger.

Student Activity

Ask the students to open their books at pages 104–105 and work through the exercises together.

Recapitulation

If possible, take the students outside, to the playground and use chalk to draw round the feet of a standing student. Then ask the same student to lie down with his/her arms outstretched while you draw round him/her. Are the two areas the same? Which is larger? If there is time, ask the students to draw round other objects to find and compare their areas.

Finding one larger Pages 106–107

Teaching Objectives

- to help students compare two similar objects by size to find the larger

Learning Outcomes

Students should be able to

- correctly identify the larger of two objects.

Lesson 45 Pages 106–107 Finding one larger

Materials required:

- pairs of objects (such as those used in the previous lesson) to compare by size;

Introduction

Use the objects to revise briefly the concept of larger than that was taught in the previous lesson.

Student Activity

Ask the students to open their books at pages 106–107.
Explain the task and work through the exercises together.

Recapitulation

Ask students to make sentences about the relative sizes of classroom objects, e.g. The board is larger than my book. Amin's bag is larger than Sohail's bag.

Note—take care to avoid personal comparisons.

Drawing one larger Pages 108–109

Teaching Objectives

- to help students draw a larger version of a given image by tracing

Learning Outcomes

Students should be able to

- draw a larger version of a given image by tracing.

Lesson 46 Pages 108–109 Drawing one larger

Materials required

- enough sets of cards made by using resource sheet 4 for students to use in pairs;

Resource sheet 4-Getting larger

Photocopy this sheet on to good quality paper or thin card and cut them up to make enough sets of cards for students to work in pairs. To keep sets separate, either use different coloured card/paper, or draw different symbols on the backs of each set.

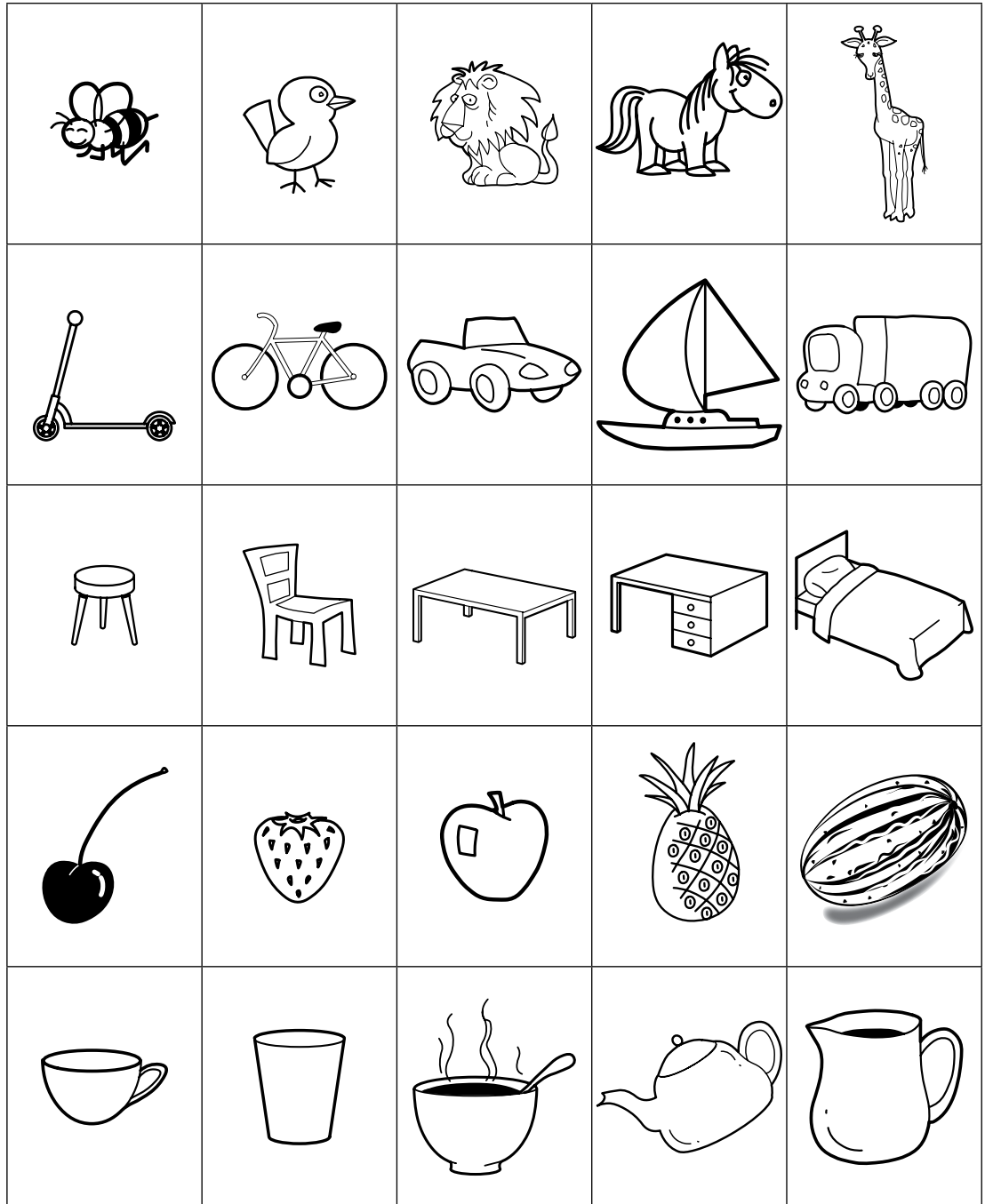

Introduction

Draw a simple shape on the board, e.g. a triangle or circle or a letter of the alphabet. Next to it draw a larger version of the same shape. Ask the students to say which of them is larger.

Draw a second, different, shape or letter and ask a student to come to the board and draw a larger version of it. Give any help that is required. Repeat this activity several times.

Student Activity

Ask the students to open their books at page 109. Explain the task and give the students a set amount of time to complete the work as accurately as possible.

Recapitulation

Play a game using the Getting Larger cards. Give each pair of students a set of cards and ask them to arrange them in order from the smallest item to the largest in the five related groups. It may be necessary to demonstrate with one of the groups first.

When they have completed the work, talk about the groups and ask if students can suggest other items that might be placed between any of the cards, e.g. a dog or cat between the bird and the lion.

Finding one heavier Pages 110–111

Teaching Objectives

- to teach the meaning of the terms *heavy* and *heavier*
- to help students compare objects by weight using the term heavier

Learning Outcomes

Students should be able to

- use the terms *heavy* and *heavier* correctly.
- compare objects by weight using the term heavier.

Lesson 47 Pages 110–111 Finding one heavier

Materials required

- two buckets partly filled with water, one heavier than the other; two bags containing books, one heavier than the other; other items that can be compared by weight, e.g. a bag of sugar, a can of soft drink, a packet of crisps, a bag of rice, a packet of sweets, a plant pot full of soil, books, etc.

Introduction

You may want to take the students outside to start this lesson since it involves water. Begin by showing them the less-heavy of the two buckets of water; lift it, demonstrating that you are using effort to do so and introduce the term *heavy*. Let each of the students try to lift the bucket. NOTE: they should be able to lift it, but not without effort.

Next, lift the first bucket and then the second bucket, and demonstrate as you lift them that the second is heavier. Ask the students to lift the buckets and decide which is heavier.

Ask them to do the same with the bags of books. Ask the students to name some other things that are heavy, e.g. an elephant, a horse, a car, etc.

Student Activity

Ask the students to open their books at pages 110–111. Explain the task and discuss the example. Then ask the students to circle the heavier item of each of the pairs. As they do so, encourage them to talk about why the item they have chosen is heavier than the other item.

Recapitulation

If there is a see-saw in the school playground, take the students out and let them sit on it in pairs to see which of any two students is the heavier (being sensitive to any students who may be particularly large or small). If there is no see-saw, hold up pairs of the items you have prepared and ask the students, or an individual student to say which of the two is heavier. Encourage them to use full sentences, e.g. The can of drink is heavier than the pencil.

Finding 'hot' things Pages 112–113

Teaching Objectives

- to teach the meaning of the terms *hot* and *cold*
- to help students identify things that are hot

Learning Outcomes

Students should be able to

- use the terms *hot* and *cold* correctly.
- identify and name things that are hot.

Lesson 48 Pages 112–113 Finding 'hot' things

Materials required

- a bowl of hand-hot water and a bowl of cold water; hand towels or paper towels; a candle; a box of matches; sheets of plain paper; crayons or coloured pencils;

Introduction

Place the two bowls of water on a table and ask the students to come one by one and quickly place a hand in each of the bowls. Talk about the different temperatures and introduce the terms hot and cold.

Show the students the unlighted candle and ask them whether it is hot or cold. Place it in a safe place and light it; ask them again if it is hot or cold. Blow out the candle. Ask the students to name other items that are hot or cold.

Student Activity

Ask the students to open their books at pages 112–113. Explain the task and discuss the example. Then ask them to circle the hot item of each of the pairs. As they do so, encourage them to talk about the items.

Recapitulation

Give the students paper and crayons or coloured pencils. Ask them to name things that are hot and then ask each of them to draw something that is hot. Use their drawings to make a classroom display.

Finding what comes first (1) and (2) Pages 114–117

Teaching Objectives

- to help students place two events in chronological sequence

Learning Outcomes

Students should be able to

- place two events in chronological sequence.

Lesson 49 Pages 114–117 Finding what comes first (1) and (2)

Materials required

- none

Introduction

Talk to the students about some of your own routines using the terms ‘First I....., and then I...’ For example,

First I eat my breakfast, then I come to school; First I make a cup of tea, then I drink it.

Include some events that are out of sequence, e.g. First I dry my hands, then I wash them; First I tie my shoe laces, then I put my shoes on. Encourage the students to say whether the sequence is correct or not. When they understand, ask them to give examples.

Student Activity

Ask the students to open their books at pages 114–117. Look at each pair of pictures and discuss what they show in order to decide which comes first. Work through each pair of pictures with the students.

Recapitulation

Ask the students to tell you about two things that they do in the correct chronological order, when they wake up, arrive at school, come into the classroom, have lunch break, go home from school, get ready for bed, etc. Encourage them to use the terms First I, then I

Finding balls Pages 118–119

Teaching Objectives

- to teach the meaning of the term *ball*
- to help students identify balls among a variety of different shapes

Learning Outcomes

Students should be able to

- use the term *ball* correctly.
- distinguish items that contain balls and items that do not.

Lesson 50 Pages 118–119 Finding balls

Materials required

- a selection of different balls, e.g. cricket ball, tennis ball, hockey ball, football, ping-pong ball, beach ball, etc.; red and blue coloured pencils or crayons;

Introduction

Display the selection of balls that you have prepared and talk about what each of them is used for. Ask the students to suggest other items that are shaped like balls, e.g. oranges, beads, some sweets, etc.

Student Activity

Ask the students to open their books at page 118 and explain the task. Make sure that the students have access to red and blue coloured pencils or crayons. Talk about the different objects that are shown.

Then look at page 119 and explain the task. Stress that they should circle the items that do not contain balls. Give the students a set amount of time to complete the task and then check their work as a class.

Recapitulation

Use a ball to play a game; ask the students to stand in a circle. Throw the ball to one student and begin to count (say 1). The student should catch the ball, and say 2, and throw the ball to another student who should continue the counting and throw the ball again. If a student fails to catch the ball or miscounts, s/he is out and should sit down. Vary the activity by counting backwards, saying the names of colours, shapes, etc.

Finding boxes Pages 120–121

Teaching Objectives

- to teach the meaning of the term *box*
- to help students identify boxes among a variety of different shapes

Learning Outcomes

Students should be able to

- use the term *box* correctly.
- distinguish items that are boxes from items that are not.

Lesson 51 Pages 120–121 Finding boxes

Materials required

- a selection of boxes of different sizes and shapes; orange and purple coloured pencils or crayons; class set of copies of My Treasure Box (resource sheet 5);

Resource sheet 5-My treasure box

Photocopy this sheet on to good quality paper or thin card.

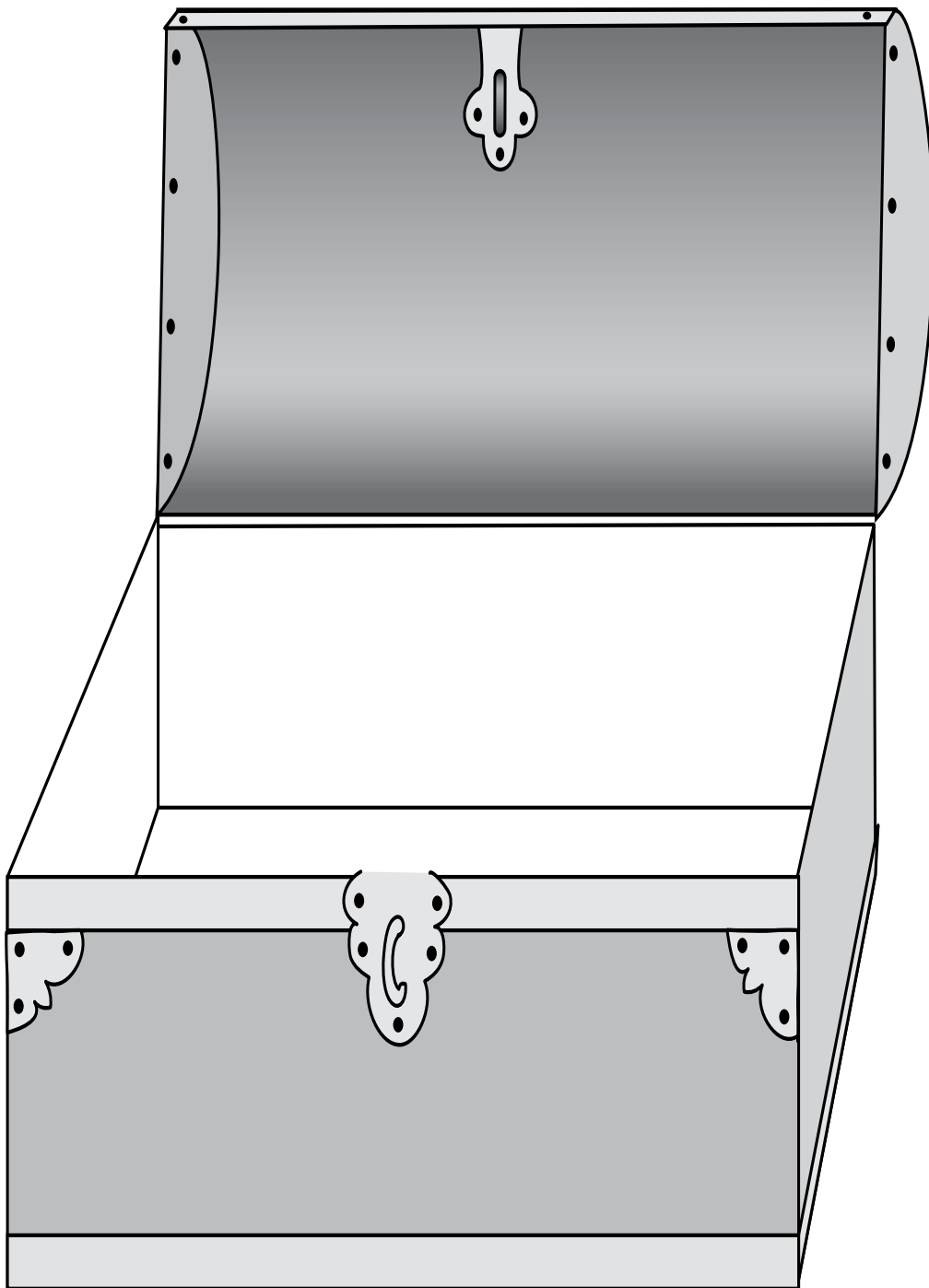

Introduction

Display the selection of boxes that you have prepared. Ask the students to count the number of sides and establish that (cuboid) boxes usually have six sides. Help the students to count the number of corners. Ask them to find other boxes in the room, e.g. box of tissues, and to talk about other boxes they may have at home—toy boxes, jewellery boxes, tool boxes, boxes of food items in the kitchen, etc.

Student Activity

Ask the students to open their books at pages 120–121. Make sure that the students have access to orange and purple coloured pencils or crayons.

This lesson can follow the structure for lesson 50.

Recapitulation

Give each student a copy of resource sheet 5. Explain that this is a box in which they can keep all their favourite things—their treasures. Talk about some of these things and then ask the students to draw their treasures in the box. The work can be used as a classroom display.

Sorting 3D shapes Pages 122–123

Teaching Objectives

- to help students understand the term *3D*

Learning Outcomes

Students should be able to

- distinguish between *2D* and *3D* shapes.

Lesson 52 Pages 122–123 Sorting 3D shapes

Materials required

- Before the lesson, prepare a collection of modelling materials by asking the students to bring from home clean, empty boxes, cardboard tubes, etc. if you do not already have a collection of these items; building blocks; balls; drawings of 2-D shapes; glue; scissors; paints; coloured pencils or crayons.

Introduction

To explain the difference between 2D and 3D shapes, show the students a drawing of a shape e.g. a rectangle, and then show them a box of a similar shape. Ask them to talk about the similarities between them and also the differences, in particular ask if you can put something inside the drawing. Show them that it has only two sides, back and front, but it contains no space inside. Do the same for a cylinder using an empty can or cardboard tube, for a ball and a circle, and any other shapes and containers you have collected.

Also demonstrate that the 3-D shapes can be stacked on top of each other, but the drawings cannot.

Student Activity

Ask the students to open their books at pages 122–123 of the textbook. Look at the picture and talk about the different shapes that are shown before asking the students to complete the colouring tasks.

Recapitulation

Ask the students to work in pairs or small groups and use the collection of boxes, etc., and glue to make models which they can paint.

This activity may be extended over several lessons.

Finding circles Pages 124–125

Teaching Objectives

- to revise the term *circle*
- to help students identify circles among a variety of different shapes

Learning Outcomes

Students should be able to

- use the term *circle* correctly.
- distinguish items that are circles from items that are not.

Lesson 53 Pages 124–125 Finding circles

Materials required

- a selection of items that have patterns of circles or contain circles, e.g. can of drink, clock, mug, pan, pot, bottle, etc.; brown and yellow coloured pencils or crayons; a selection of circular objects or templates that students can use to draw round; coloured sugar paper and chalks;

Introduction

Ask the students to draw a circle in the air as you draw a circle on the board. Show them the items that you have prepared and ask individual students to identify the circles.

Student Activity

Ask the students to open their books at pages 124–125. Make sure that they have access to brown and yellow coloured pencils or crayons.

This lesson can follow the structure for lesson 50.

On page 125 you may wish to tell the students the names of the other shapes, but it is not necessary for them to be able to use all the names at this stage.

Recapitulation

Continue the modelling activity from the previous lesson. Alternatively, provide students with coloured sugar paper, chalks, and circular objects to draw round and ask them to design a pattern of circles.

Finding squares Pages 126–127

Teaching Objectives

- to help students understand the term *square*
- to help students identify squares among a variety of different shapes

Learning Outcomes

Students should be able to

- use the term *square* correctly.
- distinguish items that are squares from items that are not.

Lesson 54 Pages 126–127 Finding squares

Materials required

- a selection of squares and rectangles of different sizes cut from coloured card; Blu-tack, masking tape or similar adhesive material; red and green coloured pencils or crayons;

Introduction

Show the students a large cut-out square and a rectangle; to make the difference obvious, the rectangle should have pairs of sides that are of very different lengths. Ask them to count the number of sides of each shape to establish that each has four sides. Ask how the shapes are different; encourage the students to think about the lengths of the sides to see that all four sides of the square are of equal length, while the rectangle has two longer sides and two shorter sides. Teach the terms square and rectangle.

Divide the board into two columns and draw a square at the top of one and a rectangle at the top of the other. Ask individual students to fix the other cut out shapes in the correct columns on the board.

Student Activity

Ask the students to open their books at pages 126–127. Make sure that they have access to red and green coloured pencils or crayons.

This lesson can follow the structure for lesson 50.

Recapitulation

Remove the shapes from the board and show them to the students, one-by-one. If the shape is a square the students should put their hands on the desk; if it is a rectangle they should raise their hands (or any other actions you wish to substitute).

Finding triangles Pages 128–129

Teaching Objectives

- to revise the term *triangle*
- to help students identify triangles among a variety of different shapes

Learning Outcomes

Students should be able to

- use the term *triangle* correctly.
- distinguish items that are triangles from items that are not.

Lesson 55 Pages 128-129 Finding triangles

Materials required

- yellow and blue coloured pencils or crayons; coloured paper, scissors and glue;

Introduction

Draw a large triangle on the board and ask the students to tell you the name of the shape. Ask them to count the number of sides (3) and the number of corners (3). Draw an open square/rectangle (□) shape on the board and count the number of sides (3), and the number of corners (2). Establish, in simple terms, that it is not a triangle because it is not a closed shape and it does not have 3 corners. Draw a selection of different triangles on the board and establish that they are all triangles.

Student Activity

Ask the students to open their books at pages 128–129 of the textbook. Make sure that the students have access to yellow and blue coloured pencils or crayons.

This lesson can follow the structure for lesson 50.

Recapitulation

Give the students coloured paper, scissors and glue and ask them to draw and cut out triangles to make patterns. Use their work to make a classroom display.

Finding rectangles Pages 130-131

Teaching Objectives

- to revise the term *rectangle*
- to help students identify rectangles among a variety of different shapes

Learning Outcomes

Students should be able to

- use the term *rectangle* correctly.
- distinguish items that are rectangles from items that are not.

Lesson 56 Pages 130-131 Finding rectangles

Materials required

- a selection of squares and rectangles of different sizes cut from coloured card (as used in lesson 54); purple and pink coloured pencils or crayons; square-dotted or squared paper; coloured pencils or crayons;

Introduction

Use the cut-out shapes to revise the difference between a rectangle and a square as taught in lesson 54.

Student Activity

Ask the students to open their books at pages 130–131. Make sure that the students have access to pink and purple coloured pencils or crayons.

This lesson can follow the structure for lesson 50.

Recapitulation

Give the students squared/square-dotted paper. Draw dots on the board and demonstrate how they can join the dots or colour the squares in different ways to make squares or rectangles. Ask them to draw and colour the shapes to make a pattern. Display their work in the classroom.

Making patterns Pages 132–133

Teaching Objectives

- to revise using two colours to make patterns

Learning Outcomes

Students should be able to

- use two colours to make a pattern.

Lesson 57 Pages 132–133 Making patterns

Materials required

- a selection of items patterned in two colours, or drawings of patterns; coloured pencils or crayons; plain, squared, and dotted paper;

Introduction

Ask the students to look back in their books, e.g. at pages 14–15 and recall how they made patterns using two colours. Show them the items or drawings you have prepared and talk about the patterns. Draw repeating shapes on the board and ask the students to suggest how you could colour them to make a pattern. Ask individual students to colour the shapes in the way suggested.

Student Activity

Ask the students to open their books at pages 132–133. Ask them to name the different shapes on the two pages and talk about the ways in which they are arranged. Ask students to suggest ways of colouring them to make a repeating pattern using two colours, before asking them to complete the work neatly and accurately.

Recapitulation

The students can continue this work, or draw their own patterns on either plain, squared or dotted paper.

Making pictures Pages 134–135

Teaching Objectives

- to help students recognize different shapes used to create pictures
- to help students combine different shapes to make pictures

Learning Outcomes

Students should be able to

- recognize different shapes used to create pictures.
- combine different shapes to make pictures.

Lesson 58 Pages 134–135 Making pictures

Materials required

- coloured pencils or crayons;

Introduction

Revise the basic shapes (square, rectangle, circle and triangle) by drawing them on the board and asking the students to name them and describe their characteristics (number of sides, corners, etc.).

Student Activity

Ask the students to open their books at pages 134–135. Look at each drawing in turn and ask the students to identify the objects and the different shapes that have been used to make each of the drawings. You could ask the students to count how many of each different shape they can see in each drawing. Ask the students to colour the drawings carefully.

Recapitulation

Carry out the activity suggested at the bottom of page 135.

Drawing something 'on top of' Pages 136–137

Teaching Objectives

- to teach the meaning of the phrase *on top of*
- to help students place or draw one item on top of another, given item.

Learning Outcomes

Students should be able to

- use the phrase *on top of* correctly.
- place or draw an item on top of another, given item.

Lesson 59 Pages 136- 137 Drawing something 'on top of'

Materials required

- building blocks, empty boxes, or other items that can be placed on top of each other;

Introduction

To teach the term on top of, place one item on top of another, e.g. a pencil case on top of a pile of books, and use the term to describe its position: the pencil case is on top of the books. Place other classroom items on top of each other and ask the students to describe where they are, using the target phrase.

Ask individual students to place one item on top of another.

Student Activity

Ask the students to open their books at pages 136–137 of the textbook. Ask them to look at the first picture and ascertain that the rider is on top of the horse. Before they complete the drawing, look at the other pictures and ask the students to suggest items that could be placed on top of those shown. Give them a set amount of time to complete the tasks.

Recapitulation

Divide the students into groups. Give each group a set of building blocks, boxes or other items and ask them to take turns to place one of them on top of another to build a tower. They should count how many items they can stack before the tower collapses. Which group can build the highest tower?

Drawing something 'between' Pages 138–139

Teaching Objectives

- to teach the meaning of the term *between*
- to help students place or draw an item between two other items

Learning Outcomes

Students should be able to

- use the preposition *between* correctly.
- place or draw an item between two other items.

Lesson 60 Pages 138-139 Drawing something 'between'

Materials required

- classroom objects;

Introduction

To introduce the term between, ask three students to stand in a line and explain that e.g. Ali is between Samira and Hossain. Line up three more students and ask 'Where is (name of middle student)? Repeat this with other groups of students.

Repeat the activity, placing one classroom object between two others. Ask individual students to place a given object between two others, e.g. Place the ruler between the red pencil and the blue pencil.

Student Activity

Ask the students to open their books at pages 138–139. Look at the example and ask the students to describe the position of the cat using the target language. Look at the other pictures and ask the students to suggest items that could be drawn between the two given objects before asking the students to complete the work.

Recapitulation

Ask the students to describe items in their homes that are between two other objects; e.g. the television is between the door and the window.

Finding your way (1) and (2) Pages 140–143

Teaching Objectives

- to help students find their way through a maze by the trial and improvement method

Learning Outcomes

Students should be able to

- find their way through a maze by the trial and improvement method.

Lesson 61 Pages 140–143 Finding your way (1) and (2)

Materials required

- a large drawing of a maze puzzle similar to those shown in the book; Blu-tack, masking tape or similar adhesive material;

Introduction

Fix the drawing of the maze puzzle on the board and explain that you need to find the way from the start to the finishing point. Attempt to do so, deliberately taking a wrong turn and returning to the start to try again. Ask students for suggestions at each junction. When you have succeeded, ask a student to come and try to trace the way with a finger.

Student Activity

Ask the students to open their books at page 140 and ask them to follow with their finger the way through the maze indicated by the dotted line. Then ask them to trace over the line with a pencil. Look at each of the remaining puzzles and trace the way through them in the same way.

Recapitulation



Ask the students to use colour to shade the paths through the mazes.

You may wish to ask students to complete Assessment sheet 2. Explain the task carefully and clearly to the students before they begin.

Assessment Sheet 2

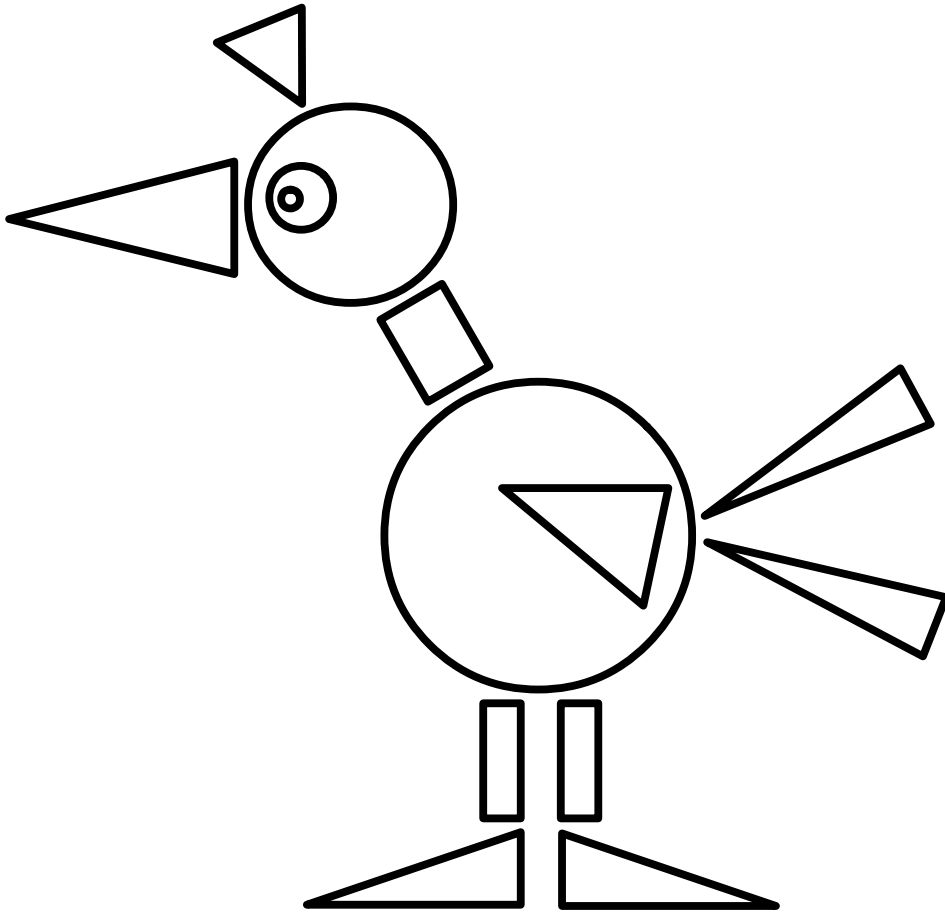
Look at the drawing and count how many of each different shape you can see. Write the number in the box next to the shape.

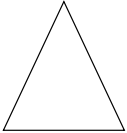
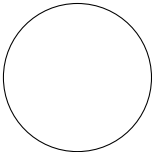

					
---	--	---	--	--	--